



Lovejoy Torsional Coupling LF Model 1, 2, & 3 Installation Guide



Model 2



Model 3

Torsional Coupling Assembly Instructions 50A and 60A Duro NBR Black Rubber Elements Only

INTRODUCTION:

The following document is intended for the explicit use of Lovejoy customers to aid in the installation of Lovejoy products. The information may be considered privileged and should only be disseminated as an active part of conducting business with Lovejoy, LLC.

PRODUCTS:

This document is designed to aid in the assembly and installation of the Lovejoy LF torsional coupling product line, Models 1, 2, and 3; both standard and 'S' Style. This document is not meant as reference for installing LF couplings with Hytrel or Zytel elements.

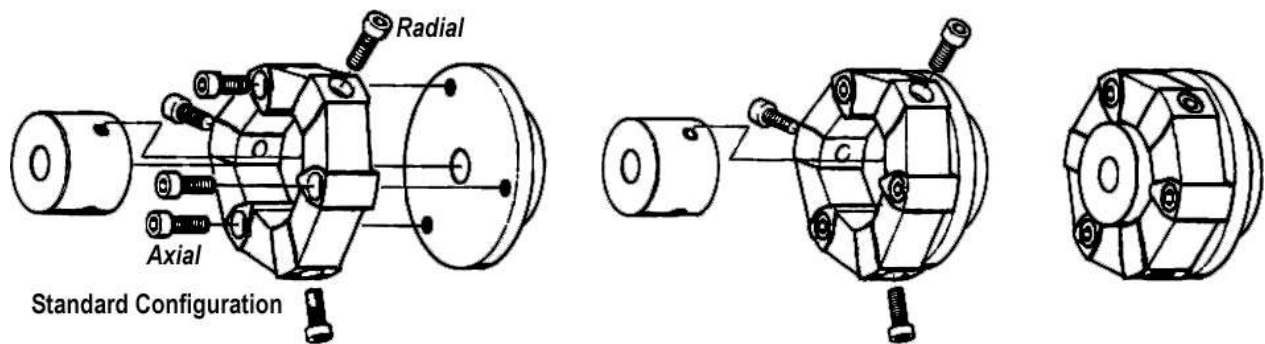

Figure 1

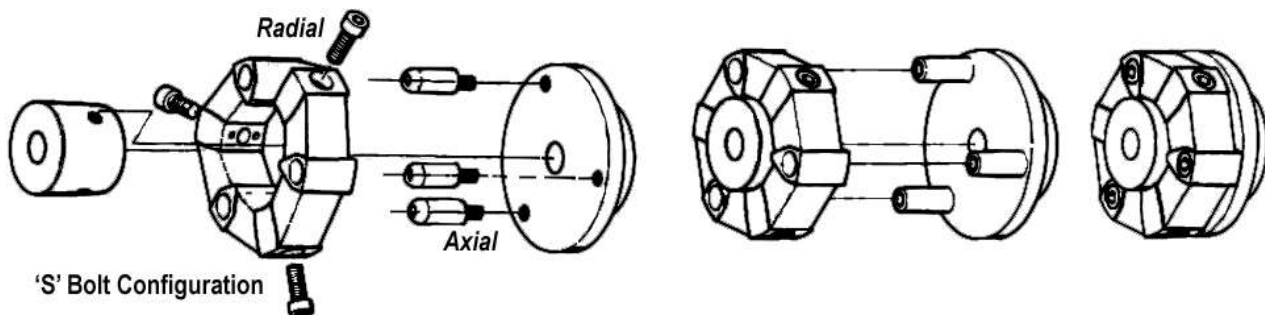

Figure 2

INSTALLATION PROCEDURE:

Please review all instructions before starting work. Comprehensive safety warnings can be found in Lovejoy Torsion Products Catalog, Section T-2 [<https://www.lovejoy-inc.com/wp-content/uploads/2018/01/Torsional2010.pdf>]

1. Prior to Installation, inspect the coupling to ensure you have all the necessary parts. Also, inspect hub bores and key slots to make sure they are free of burrs. Ensure the key fits properly in both the shaft and hub keyways.
2. Place the hubs on the engine and equipment shafts, then secure with set screws using the torque values listed in Table 1. Ensure the keys have been inserted and are flush with the ends of the shafts. Model 3 installations use a flywheel adapter and the adapter should already have threaded holes for the axial bolts. If the mounting holes are not threaded, install the element with the cap screws or the S-bolts using nuts on the backside of the adapter before mounting the adapter on the flywheel.

Since most adapter plate mounting holes will be threaded or have nuts welded to the back side of the plate, install the adapter on the flywheel. Then install the element with the axial cap screws or S-bolts finger tight only. It is usually a good idea to place a small amount of non hydrocarbon lubricant under the head of the cap screws to prevent the inserts from twisting (See figure 3) when its time to tighten these screws to their specified torque. **Avoid using hydrocarbon based grease or oil around the LF elements.**

If you are using hubs or flange adapters that were not supplied by Lovejoy, ensure there is no axial pressure (lengthwise) on the rubber element when installation is complete. All parts must meet Lovejoy specifications.

If the hubs have L-LOC spline clamping set screws, see Table 2 for instructions when installing hubs with L-LOC.

3. Attach the rubber element to the flange hub, flange adapter plate, or flywheel using the axial screws as shown in Figure 3. Only tighten these screws finger tight at this time. If this is the S-Style element, you will need to install the S-Pins on the flywheel or flywheel adapter without the element in place. The S-Pins can be tightened to the specified torque defined in Table 1.
4. Slide the cylindrical hub inside the element and install the radial screws finger tight only. Apply a small amount of lubricant under the head of the radial cap screws prior to installing these screws. This will help guard against the radial inserts from twisting when these screws are tightened. There will be some clearance space between the hub and element. This allows for the element to compress when the radial screws are tightened to the specified torque. If this installation is using S-Pins, apply a very light coat of lubricant on the S-pins and slide the element onto the S-Pins. **Avoid using hydrocarbon based grease or oil around the LF elements.**
5. Tighten the axial screws first. Make sure there is some non hydrocarbon lubricant under the head of the screw before inserting the screw through the element. See Table 1 for the proper torque values to use when tightening these screws. While tightening these screws, watch the inserts to ensure the inserts are not twisting or trying to rotate. See Figure 3, right side.

Note: DO NOT use anaerobic adhesives such as Loctite or Omnifit on any screws or parts of this coupling. Anaerobic adhesives attack the bonds between the rubber elements and metal inserts in the coupling and will cause premature failure of the coupling.

6. Again, use a small amount of a non hydrocarbon lubricant under the head of each screw before inserting the screw through the element. Partially tighten the radial screws (use a criss-cross pattern for the four bolt elements) and repeat getting slightly tighter each time around the pattern. The final tightening pass should be completed using the torque values specified in Table 1.

Note: Ensure the inserts in the element are not twisted as shown in Figure 3, top left. If the insert is twisted, it will not seat properly on the cylindrical hub and the bolts will come loose causing premature failure.

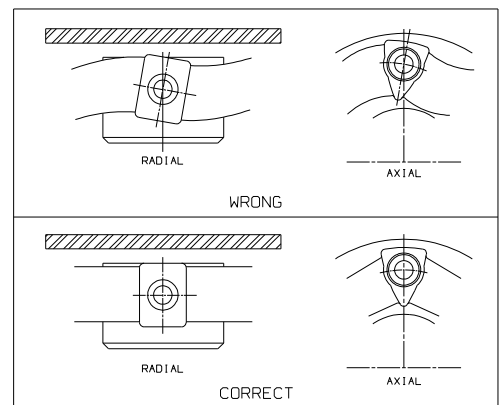

Figure 3

Precautions:

a. All screws connecting the element to the hubs or flanges must be tightened with a calibrated torque wrench using the values specified in Table 1. The correct tightening torque is particularly important on larger size couplings. **Tightening by feel is not acceptable and will not be sufficient.**

b. When tightening the screws make sure the aluminum inserts or rubber arms are not twisted (see figure 4). To reduce the friction between the screw head and aluminum insert, place a drop of a non-hydrocarbon lubricant under the bolt heads prior to tightening. **If the inserts are twisted (see figure 3), the radial inserts may not seat properly on the cylindrical hub or spacer shaft. If this happens the curved surface of the hub will not seat properly on the hub and will not carry the load with the full surface of the insert. When this happens, all the radial screws can loosen and the coupling will fail.**

c. **Use of anaerobic adhesives such as Loctite, Omnifit, etc. will attack the bond between the rubber element and the cushion inserts and cause the coupling to fail. DO NOT use anaerobic adhesives.** The bolts shipped with the coupling have a dry adhesive applied to the threads. Once bolts have been used and/or removed from the coupling for any reason, the bolts with the adhesive cannot be reused effectively. The adhesive is factory applied and cannot be applied in the field. Once these bolts are removed, contact Lovejoy customer service for replacements bolts.

d. S-Style elements can be installed backwards very easily. Care should be taken to ensure the standoffs are facing the flanged hub, flywheel adapter, or flywheel. The Lovejoy logo should be clearly visible facing outward. There should be gap between the element and flange as shown in figure 4. The dimension for this gap is defined in table 3.

e. Check the alignment of the coupling to help prevent premature failure. If the coupling is using a flange style hub, a dial indicator can be used to check alignment across the top of the element and edge of the flange hub. Checking alignment with a straight edge is not the recommended procedure, however it will help in checking to see if alignment might have changed during the installation process.

f. **Angular misalignment should not exceed +/- 2° for 4 screw elements and should not exceed +/- 3° for 2 and 3 screw elements.**

See Table 3 for a complete list specifications for the LF couplings including the alignment specifications and dimensional details for the axial bolt circle.

g. The coupling is susceptible to environmental conditions that may not be suitable for the rubber element. Temperatures between 120° and 180° could cause the torque capacity of the coupling to be 'de-rated' and temperatures above 180° may cause breakdown of the rubber. **The coupling should never be subjected to direct contact with engine oil, hydraulic oil, petroleum based fluids, or any hydrocarbon based lubricants.**

h. Care should be taken to protect the rubber elements from exposure to UV light. **UV light will cause the element to break down and fail prematurely.**

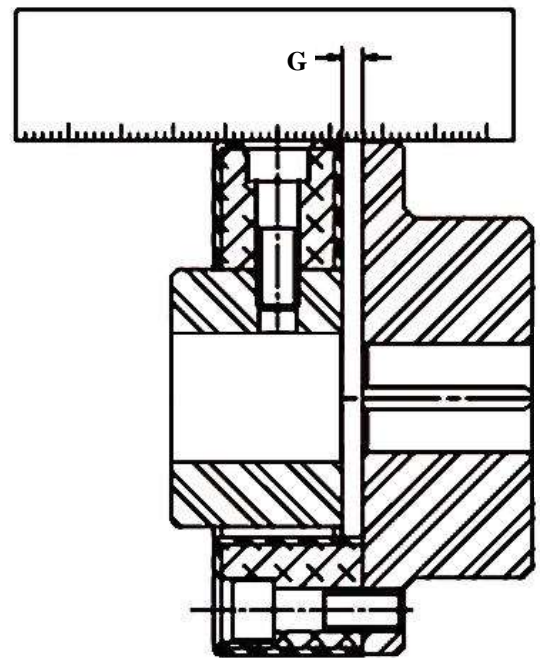

Figure 4

TABLE 1:

Torsional Coupling Size	1	2	4	8	16	30	50	90	140	250
Axial Screws Type Model 6	M6 x 25	M8 x 20	M8 x 25	M10 x 30	M12 x 35	M16 x 50	M16 x 50	M20 x 65	M20 x 65	M20 x 80
Axial Screws Type 6B	M6 x 30	M8 x 25	M8 x 30	M10 x 35	M12 x 40	M16 x 55	M16 x 55	M20 x 70	M20 x 70	M20 x 85
Axial Screws Type 'S'	M6 x 25	M8 x 30	M8 x 30	M10 x 35	M12 x 45	M16 x 60	M16 x 60	M20 x 70	M20 x 70	M20 x 85
Radial Screws (All)	M6 x 10	M8 x 20	M8 x 25	M10 x 30	M12 x 35	M16 x 50	M16 x 50	M20 x 65	M20 x 65	M20 x 80
Screw Tightening Torque	7 ft-lbs	20 ft-lbs	20 ft-lbs	40 ft-lbs	65 ft-lbs	150 ft-lbs	150 ft-lbs	330 ft-lbs	330 ft-lbs	330 ft-lbs
Set Screw Size	M6	M8	M8	M10	M12	M16	M16	M20	M20	M20
Set Screw Torque	7 ft-lbs	13 ft-lbs	13-ft-lbs	20 ft-lbs	35 ft-lbs	90 ft-lbs	90 ft-lbs	150 ft-lbs	150 ft-lbs	150 ft-lbs
Gap dimension to use for 'G'	2 mm .08 in	4 mm .16 in	4 mm .16 in	4 mm .16 in	6 mm .24 in	8 mm .31 in	8mm .31 in	8mm .31 in	8mm .31 in	8mm .31 in

TABLE2:

When tightening the set screws in the L-LOC option, ensure the spline shaft is fully engaged and completely under both L-LOC set screws. **If the spline shaft is not long enough to extend under one of the set screws, DO NOT tighten that set screw.** Some cylindrical hubs may only have a single L-LOC set screw. The spline shaft must extend fully beneath that set screw before tightening. For torque values, see the chart below.

Torsional Coupling Size	1	2	4	8	16	30	50	90	140	250
L-LOC Feature	-	-	-	M10	M12	M16	M16	M20	M20	M20
Set Screw Torque	-	-	-	20 ft-lbs	30 ft-lbs	90 ft-lbs	90 ft-lbs	150 ft-lbs	150 ft-lbs	150 ft-lbs

TABLE 3:

Torsional Coupling Size	Element Material	Angular Degrees	Parallel	Axial Stnd (End Float)	Axial S-Bolt (End Float)	Number of Bolts (Axial)	Bolt Circle Diameter	'G' Gap Dimension
LF1	HTR	3	.060" (1.5mm)	+/- .080" (+/- 2mm)	+ .180" / -.080" (+4.6mm / -2mm)	2 @ 180°	1.730"	.080"
LF2	HTR	3	.060" (1.5mm)	+/- .120" (+/- 3mm)	+ .120" / -.120" (+3mm / -3mm)	2 @ 180°	2.680"	.160"
LF4	HTR	3	.060" (1.5mm)	+/- .120" (+/- 3mm)	+ .170" / -.120" (+4.3mm / -3mm)	3 @ 120°	3.150"	.160"
LF8	HTR	3	.080" (2mm)	+/- .160" (+/- 4mm)	+ .200" / -.160" (+5mm / -4mm)	3 @ 120°	3.940"	.160"
LF12	HTR	2	.080" (2mm)	+/- .120" (+/- 3mm)	+ .200" / -.160" (+5mm / -4mm)	4 @ 90°	3.940"	.160"
LF16	HTR	3	.080" (2mm)	+/- .200" (+/- 5mm)	+ .230" / -.200" (+5.8mm / -5mm)	3 @ 120°	4.920"	.240"
LF22	HTR	2	.080" (2mm)	+/- .120" (+/- 3mm)	+ .230" / -.200" (+5.8mm / -5mm)	4 @ 90°	4.920"	.240"
LF25	HTR	3	.080" (2mm)	+/- .200" (+/- 5mm)	+ .260" / -.200" (+6.6mm / -5mm)	3 @ 120°	5.510"	.240"
LF28	HTR	2	.080" (2mm)	+/- .120" (+/- 3mm)	+ .260" / -.200" (+6.6mm / -5mm)	4 @ 90°	5.510"	.240"
LF30	HTR	3	.080" (2mm)	+/- .200" (+/- 5mm)	+ .260" / -.200" (+6.6mm / -5mm)	3 @ 120°	6.500"	.310"
LF50	HTR	3	.080" (2mm)	+/- .200" (+/- 5mm)	+ .260" / -.200" (+6.6mm / -5mm)	4 @ 90°	6.500"	.310"
LF80	HTR	2	.060" (1.5mm)	+/- .200" (+/- 5mm)	+ .260" / -.120" (+6.6mm / -3mm)	4 @ 90°	6.500"	.160"
LF90	HTR	3	.080" (2mm)	+/- .200" (+/- 5mm)	+ .340" / -.200" (+8.6mm / -5mm)	3 @ 120°	8.460"	.310"
LF140	HTR	2	.080" (2mm)	+/- .200" (+/- 5mm)	+ .340" / -.200" (+8.6mm / -5mm)	4 @ 90°	8.460"	.310"
LF250	HTR	2	.080" (2mm)	+/- .200" (+/- 5mm)	+ .400" / -.200" (+10mm / -5mm)	4 @ 90°	11.020"	.310"

