

Lovejoy Torsional Coupling LF Model 6 Installation Guide

Torsional Coupling Assembly Instructions

INTRODUCTION:

The following document is intended for the explicit use of Lovejoy customers to aid in the installation of Lovejoy products. The information may be considered privileged and should only be disseminated as an active part of conducting business with Lovejoy, LLC.

PRODUCTS:

This document is designed to aid in the assembly and installation of the Lovejoy LF Model 6 product line, including the LF Model 6 (Figure 1), and Model 6B (Figure 2) with the bearing flange.

Figure 1

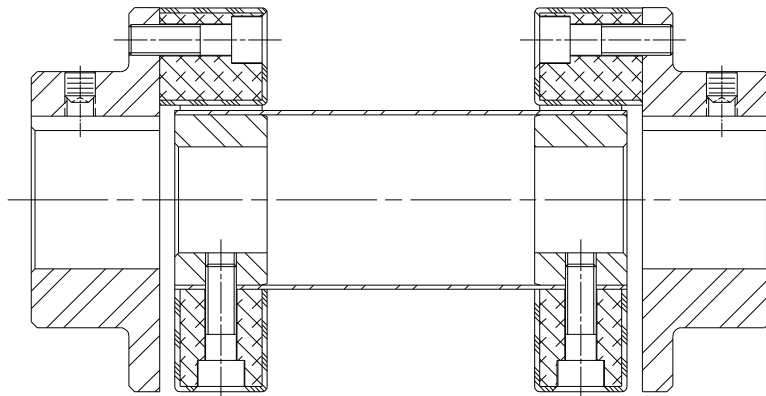
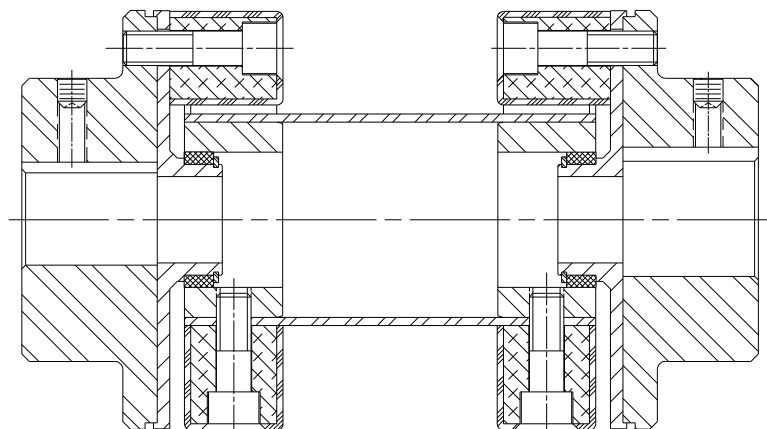

Figure 2



INSTALLATION PROCEDURE:

Please review all instructions before starting work. Comprehensive safety warnings can be found in Lovejoy Torsion Products Catalog, Section T-2 [<https://www.lovejoy-inc.com/wp-content/uploads/2018/01/Torsional2010.pdf>]

1. Prior to Installation, inspect the coupling to ensure you have all the necessary parts. Also, inspect hub bores and key slots to make sure they are free of burrs. Ensure the key fits properly in both the shaft and hub keyways.
2. Make note of the 'L' value or 'shaft separation' value for the coupling. The hubs will need to be mounted on the shafts with consideration for shaft separation, pilots, thermal expansion when in use, and the use of 'S'-Style pins when required. When installing LF Spacer couplings, note that the 'S' Style screws, or pins, allow for axial float.
3. Place the flanged hubs on the engine and equipment shafts and secure with set screws using the torque values in Table 1. Ensure the keys are inserted and flush with the ends of the shafts. If you are using hubs that were not supplied by Lovejoy, or hubs which are piloted to the coupling, ensure there is no axial pressure (lengthwise) on the elements when installation is complete. If the hubs have L-LOC spline clamping set screws, see Table 2 regarding instructions for tightening the L-LOC set screws.

4. **The coupling spacer assembly is factory assembled and should not be disassembled unless servicing or replacing components.** Disassembling this coupling and reinstalling the elements could have an adverse effect on the integrity of this coupling. Assembly without new hardware, proper assembly techniques, and accurate torque measurements, will affect the performance and warranty of this product. The following steps should be used as guidelines for the proper installation of the LF elements should they need to be replaced. Screw tightening torque values are listed in Table 1 at the end of this document.

5. Attach the rubber element to the flange hub using the axial screws as shown in Figure 3. If this is the S-Style end of the coupling (not the cap screws), you will need to install the S-Pins without the element in place and proceed to the next step. Refer to Table 1 for the proper torque values when tightening these screws. Do not completely tighten these screws at this time.

Note: The length of the cap screws is important. The axial screws are typically longer than the radial screws on the end of the coupling with axial bolts, not S style. Always use the shorter bolts as radial fasteners, i.e. as into the cylindrical hub or floating shaft.

6. Mount the element on the cylindrical hub or floating shaft by sliding the element over the shaft and insert the radial bolts. Apply a drop of a non hydrocarbon based lubricant under the head of the cap screw and insert the screw thru the radial openings in the element. Start threading the screws a couple turns into each of the radial holes in the cylindrical hub or floating shaft, but do not tighten the screws at this time.

7. Tighten the axial screws to the prescribed torque shown in Table 1. Alternate tightening the bolts around the element. Partially tighten each screw, then fully tighten the screws based on the torque values displayed in Table 1. Use alternate bolt pattern for four bolt elements.

Note 1: Refer to Figure 4 and ensure the aluminum inserts or bushings in the element are not distorted or twisted in any way. **If the inserts are twisting the rubber portion of the element, the coupling will fail prematurely.**

Note 2: DO NOT use anaerobic adhesives on any screws or parts of this coupling. Anaerobic adhesives attack the bonds between

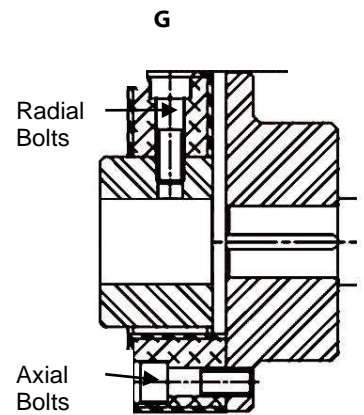

Figure 3

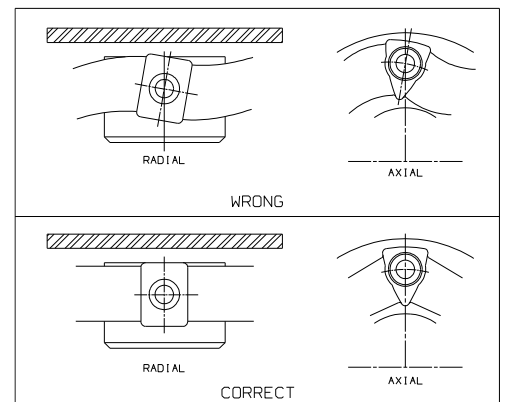

Figure 4

8. Once the axial screws have been tightened, rotate the elements and floating shaft and tighten each of the radial screws until they are snug. When tightening the screws to their prescribed torques, it will be necessary to prevent twisting of the element (figure 4) by restraining the insert with a proper tool that will not score or damage the rubber coating on the insert. Repeat this process to tighten each of the screws to roughly one half the torque value listed in Table 1. Finally, repeat once the procedure once again tightening each screw to the designated full torque amount.

Note: On the OS element using the S-Style pins, ensure the side of the element with the two different heights of corner inserts is facing the flange or bearing plate. The Lovejoy logo will face outwards and should be visible after the installation. The proper gap for the radial pads is shown in Table 1 and can be measured as seen in Figure 5.

PRECAUTIONS:

a. The axial screws are longer than the radial screws for the 'S' type and floating shaft type couplings. It is always necessary to compare the screw lengths and use the shorter screws for the radial connections into the cylindrical hub or floating shaft (see figure 3).

b. When tightening the screws make sure the aluminum inserts or rubber arms are not twisted (see figure 4). To reduce the friction between the screw head and aluminum insert, place a small amount of a non hydrocarbon based lubricant under the bolt heads prior to tightening. If the inserts are twisted, the radial inserts may not seat properly on the cylindrical hub or spacer shaft. If this happens the hub will not carry the load with the full surface of the insert. When this happens, the other radial screws can loosen and the coupling will fail.

c. If the coupling is delivered assembled, DO NOT disassemble. If the coupling needs to be disassembled to replace the elements, replace the elements and all fastening hardware (screws, pins, sleeves, etc.).

d. All screws connecting the element to the hubs or flanges must be tightened with a calibrated torque wrench using the values specified in Table 1. The correct tightening torque is particularly important on larger size couplings. Tightening by feel is not acceptable and will not be sufficient.

e. **Use of anaerobic adhesives such as Loctite, Omnifit, etc. will attack the bond between the rubber element and the cushion inserts and cause the coupling to fail. DO NOT use this type of adhesive.** The bolts shipped with the coupling have a dry adhesive applied to the threads. Once bolts have been used and/or removed from the coupling for any reason, the bolts with the adhesive cannot be reused effectively. The adhesive is factory applied and cannot be applied in the field.

f. With Model 6 shaft couplings, the alignment of the shafts will need to be completed prior to installation. Once the installation is completed, check the alignment at each end of the coupling to help prevent premature failure. If the coupling is using a flange style hub, a dial indicator can be used to check alignment across the top of the element and edge of the flange hub. Checking alignment with a straight edge is not the recommended procedure, however it will help in checking to see if alignment might have changed during the installation process. **Angular misalignment should not exceed +/- 2° for 4 screw elements and should not exceed +/- 3° for 2 and 3 screw elements.**

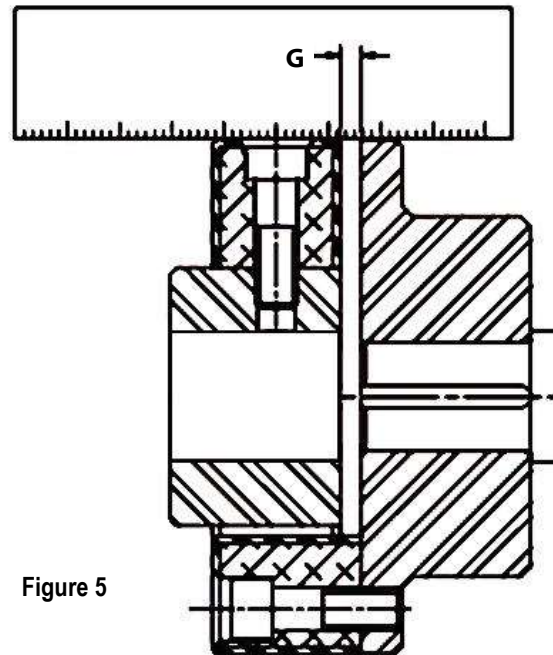

Figure 5

g. A feature of the LF Model 6 coupling is that the coupling is virtually maintenance free and does not need lubrication. The coupling is susceptible to environmental conditions that may not be suitable for the rubber element. Temperatures between 120° and 180° could cause the torque capacity of the coupling to be 'derated' and temperatures above 180° may cause breakdown of the rubber. **The coupling should never be subjected to direct contact with engine oil, hydraulic oil, or petroleum based fluids.**

f. Care should be taken to protect the rubber elements from exposure to UV light. **UV light will cause the element to break down and fail prematurely.**

TABLE 1:

Torsional Coupling Size	1	2	4	8	16	30	50	90	140	250
Axial Screws Type Model 6	M6 x 25	M8 x 20	M8 x 25	M10 x 30	M12 x 35	M16 x 50	M16 x 50	M20 x 65	M20 x 65	M20 x 80
Axial Screws Type 6B	M6 x 30	M8 x 25	M8 x 30	M10 x 35	M12 x 40	M16 x 55	M16 x 55	M20 x 70	M20 x 70	M20 x 85
Axial Screws Type 'S'	M6 x 25	M8 x 30	M8 x 30	M10 x 35	M12 x 45	M16 x 60	M16 x 60	M20 x 70	M20 x 70	M20 x 85
Radial Screws (All)	M6 x 10	M8 x 20	M8 x 25	M10 x 30	M12 x 35	M16 x 50	M16 x 50	M20 x 65	M20 x 65	M20 x 80
Screw Tightening Torque	7 ft-lbs	20 ft-lbs	20 ft-lbs	40 ft-lbs	65 ft-lbs	150 ft-lbs	150 ft-lbs	330 ft-lbs	330 ft-lbs	330 ft-lbs
Set Screw Size	M6	M8	M8	M10	M12	M16	M16	M20	M20	M20
Set Screw Torque	7 ft-lbs	13 ft-lbs	13 ft-lbs	20 ft-lbs	35 ft-lbs	90 ft-lbs	90 ft-lbs	150 ft-lbs	150 ft-lbs	150 ft-lbs
Gap dimension to use for 'G'	2 mm .08 in	4 mm .16 in	4 mm .16 in	4 mm .16 in	6 mm .24 in	8 mm .31 in	8mm .31 in	8mm .31 in	8mm .31 in	8mm .31 in

TABLE2:

When tightening the set screws in the L-LOC option, ensure the spline shaft is fully engaged and completely under both L-LOC set screws. **If the spline shaft is not long enough to extend under one of the set screws, DO NOT tighten that set screw.** Some cylindrical hubs may only have a single L-LOC set screw. The spline shaft must extend fully beneath that set screw before tightening. For torque values, see the chart below.

Torsional Coupling Size	1	2	4	8	16	30	50	90	140	250
L-LOC Feature	-	-	-	M10	M12	M16	M16	M20	M20	M20
Set Screw Torque	-	-	-	20 ft-lbs	30 ft-lbs	90 ft-lbs	90 ft-lbs	150 ft-lbs	150 ft-lbs	150 ft-lbs

Lovejoy, LLC
 2655 Wisconsin Avenue
 Downers Grove, IL 60515
 630-852-0500
 info@lovejoy-inc.com



www.lovejoy-inc.com

ISO 9001 Certified
 P/N: 68514450492 22Dec2020