

⚠ WARNING

Failure to observe the following warnings could create a risk of death or serious injury.

Installation and Service should only be performed by qualified personnel. All owner/employer safety rules must be strictly followed when working on this equipment. Please read and become familiar to this entire installation guide before beginning any work. Before working on equipment, turn off and lock out/tag out energy source and bleed off all stored energy sources. It is recommended that the chain or belt guards be installed before making a test run.

Mounting Information

- ◆ The tensioner should always be mounted on the slack (non-drive) side.
- ◆ The tensioner should always be mounted with the idler sprocket positioned between the arms.
- ◆ The idler sprocket should be positioned approximately 1/3 of the center distance from the drive sprocket.
- ◆ **Chain Drives:** position the idler sprocket on the **outside** of the drive and engage at least three teeth in the chain.
- ◆ **V-Belt Drives:** Position the idler pulley on the **inside** of the drive.

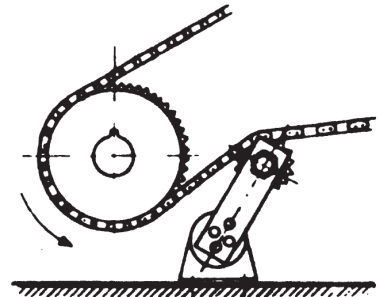

Fig. 1

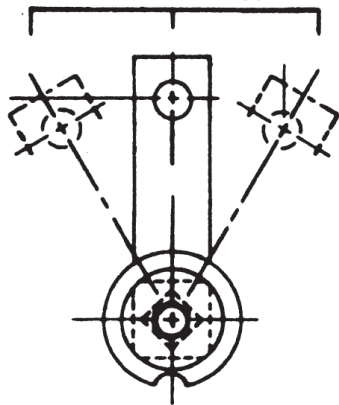

Fig. 2

- ◆ The tensioner is mounted with a single bolt and can be rotate 360° to any position around the mounting hole
- ◆ The tensioner is designed to deflect up to 30° either side of its normal position.
- ◆ A mounting hole must be drilled to meet all of the above requirements and correspond to the mounting bolt size.
- ◆ Mount the tensioner and align the idler sprocket or pulley to the chain or belt. Once it is aligned, firmly tighten the idler position nuts on the idler bolt.
- ◆ The notch in the hex portion of the base is provided as an aid to locating and is not intended to secure the base.

MOUNTING BOLT

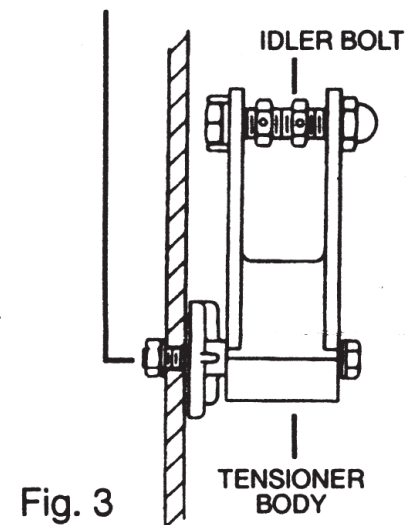

Fig. 3

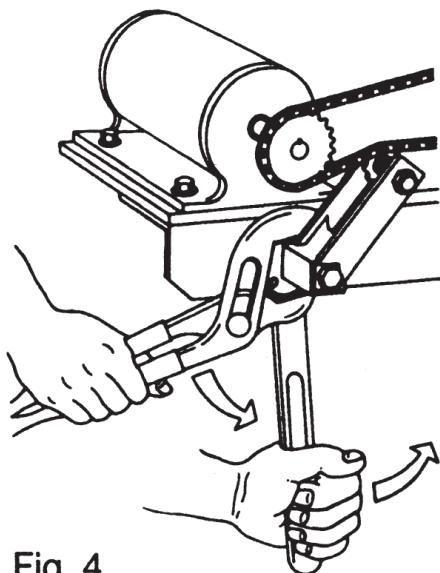

Fig. 4

- ◆ To adjust the tensioner, place a channel-lock pliers on the hx portion of the tensioner body and a second wrench on the mounting bolt.
- ◆ Apply pressure to the hex portion of the tensioner in the appropriate direction until the chain or belt is properly tensioned. (Fig.4)
- ◆ While holding the tensioner hex in position, tighten the mounting bolt to the recommended securing torque.
- ◆ Check the nuts on the idler bolt for tightness before starting the drive.
- ◆ After starting the drive, visually inspect the tensioner for alignment and proper tensioning.

Product Information

The RunRight Elastomeric Tensioner is continuously self-adjusting, dampens harmful drive vibration and does not require lubrication. The tensioner can fit a variety of chain and belt tensioning applications. It can be used and adapted for a wide variety of tensioning requirements such as limiting devices, scrapers, and cushioning devices.

Sizing Table

| ASA Chain Size | V-Belt Size | Flat Belt Width | Tensioner Model Number |
|--|-------------|-----------------|------------------------|
| For applications smaller than ASA 25 chain and "A" belts | | | RT P-7 |
| 25 S, D, T | A | - | RT 11/RT P 11 |
| 35 S, D, T | B | - | RT 15 |
| 35 S, D, T 40 S, D, T 41 S, D, T | B | 1" 2" | RT 18 |
| 40 T, 41 T 50 S, D, T 60 S, D, T | - | 2" 3" 4" | RT 27 |
| 80 S, D, T | - | 4" 5" | RT 38 |
| 80 T 100 S, D, T 120 S, D, T | - | 5" 6" | RT 45 |
| 160 S, D 180 S, D 200 S, D | - | - | RT 45 |
| 160 T, 180 T, 200T, 240 S, D | - | - | RT 50 |

S = Single Strand D = Double Strand T = Triple Strand

Mounting Information

| Tensioner Model Size | Mounting Bolt Size (Metric) | Drill Hole for Mounting | Securing Torque for Mounting Bolt (in/lbs) | Idler Bolt Size (U.S.) |
|----------------------|-----------------------------|-------------------------|--|------------------------|
| RT P7 | M4 x 40 | 11/64" | 25 | 1/4—20 x 1 |
| RT 11 | M6 x 20 | 1/4" | 89 | 3/8—16 x 2 |
| RT P11 | 1/4—20 x 2-3/4 | 17/64" | 90 | 3/8—16 x 3 |
| RT 15 | M8 x 25 | 5/16" | 221 | 1/2—13 x 2 |
| RT 18 | M10 x 30 | 7/16" | 434 | 1/2—13 x 2-1/2 |
| RT 27 | M12 x 40 | 1/2" | 761 | 1/2—13 x 3-1/2 |
| RT 38 | M16 x 40 | 5/8" | 1859 | 3/4-10x5 |
| RT 45 | M20 x 50 | 13/16" | 3629 | 3/4—10 x 6 |
| RT 50 | M24 x 60 | 1" | 6638 | 3/4—10 x 6 |

