

## General Mounting Guidelines

### Chain Drives

- ◆ Always mount Tensioner on the **SLACK** side of the chain drive.
- ◆ Typically used with Idler Sprockets, not recommended with Chain Riders.
- ◆ Chain goes under one idler sprocket and over the other idler sprocket.
- ◆ The Mounting surface must be strong, flat and large enough for the entire tensioner base.
- ◆ Ensure that the chain IS NOT rubbing on the center housing of the tensioners.

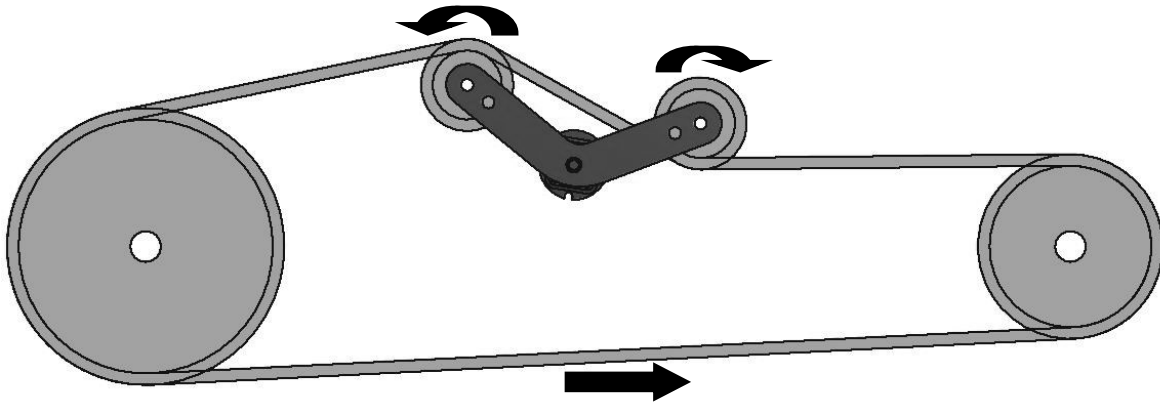

### V-Belt Drives

- ◆ Always mount Tensioner on the **SLACK SIDE** of the belt drive.
- ◆ Usually used with One Flat Roller and one V-Groove Idler with bearings.
- ◆ Use Flat Idler Roller on **OUTSIDE** of belt. Use V-Groove Idler on inside of belt.
- ◆ The Mounting surface must be strong, flat and large enough for the entire diameter of the tensioner base.
- ◆ Ensure that the belt IS NOT rubbing the center housing of the tensioner.

### Standard (back) Mounted

- ◆ Requires access to the mounting bolt from behind the equipment.
- ◆ Mounting bolt passes through mounting plate from behind and screws into the tensioner base.

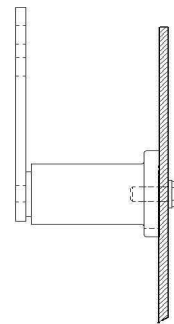

# RT-B Tensioners

### Mounting Instructions

**⚠ WARNING**

Failure to observe the following warnings could create a risk of death or serious injury.

Follow all appropriate Lock-Out/Tag-Out procedures.

It is recommended that the chain or belt guards be installed before making a test run.

1. Hold the tensioner against the mounting surface to determine the optimal position/location per the above General Mounting Guidelines.
2. Mark where the hole needs to be drilled.
3. **STANDARD MOUNTING** —Drill the mounting hole to the correct size for the Tensioner per Table 1.
4. Mount the tensioner, however, do not fully tighten the mounting bolt. Tensioner should be snug but still able to be rotated.
5. Install the mounting bolts into one of the two holes in the tensioner arm. The hole farthest out on the arm is the **NORMAL** position. The hole closest to the tensioner housing is the **HARD** position.
6. Install the appropriate accessory (sprocket, roller, pulley) for the type of drive being tensioned.
7. Align the tensioning accessory with the belt or chain and lock in place using the supplied jam nuts on each side of the accessory.
8. With a large open end wrench or pipe wrench, turn the outer housing of the tensioner until the belt or chain begins to tension.
9. Continue turning the outer housing to pre-tension the drive until the proper amount of tension has been applied, using the pretension angle markings located on the corner of the outer housing as a reference. **DO NOT EXCEED 30 DEGREES** of pre-tension!
10. While holding the tensioner in the pre-tensioned position with the open end wrench, Tighten the mounting bolt to the proper torque per Table 1.

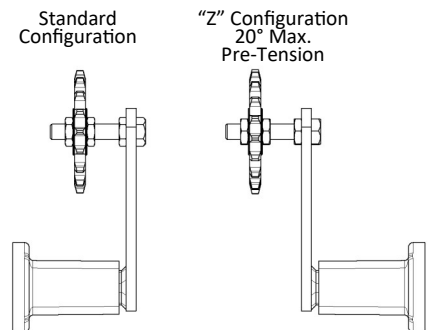
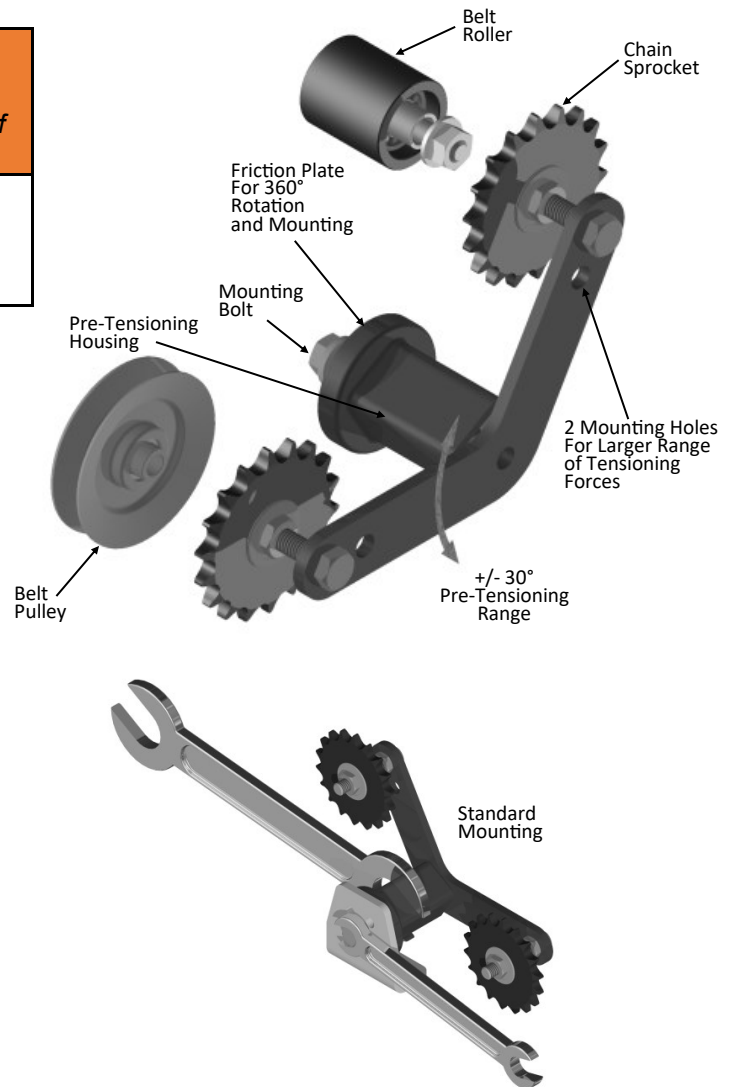

**Table 1: Mounting Information**

Tensioner Size	Mounting Bolt Size		Hole Size		Bolt Torque in/lbs	
	Standard	Front	Standard	Front	Standard	Front
RT B18	M10X30	M8	7/16"	M8X1.25	434	221
RT B27	M12X40	M10	1/2"	M10X1.5	761	434