



SAGA Torsional Coupling Installation Guide

INTRODUCTION:

The following document is intended for the explicit use of Lovejoy customers to aid in the installation of Lovejoy power transmission products. The information may be considered privileged and should only be disseminated as an active part of conducting business with Lovejoy, Inc.

SAFETY:

Accidents involving rotating equipment may result in loss of life, serious bodily harm, or property damage. The purchaser of this equipment must assure that the equipment is properly assembled, installed, safeguarded, operated, and maintained. This equipment should never be operated at or subjected to conditions that exceed manufacturer's specifications.

Consult all applicable Federal, State and local laws and regulations covering the safe operation and maintenance of equipment, including, without limitation, the USDOL-OSHA "Lockout / Tag-out" procedure set forth in 29 CFR 1910.147.

Because of the possible danger to persons or property from accidents which may result from the improper use or unapproved modifications of the product, this product must be installed, maintained and operated in accordance with the procedures, standards, and engineering specifications specified in the product literature. To assure safe operation, this product should be inspected in accordance with the instructions described in this document. Proper guards and any suitable safety equipment or procedures as may be necessary, or as may be specified in safety codes, should be installed by the user. Safety equipment and shields are not provided, nor are they the responsibility of Lovejoy, Inc.

INSTALLATION PROCEDURE:

1. Prior to Installation, inspect the coupling to ensure all the necessary parts were shipped. The coupling typically consists of 2 hubs with set screws, one element with a metal band around the outside, and either 6 or 8 bolts with lock washers.

2. Measure the hub bores to ensure they match the correct size as originally specified and ordered. Note that hubs are shipped with clearance fit bores unless otherwise specified during the purchase process. Prior to installation, inspect hub bores and key slots to make sure they are free of burrs. Ensure the key fits properly in both the shaft and hub keyways.

Note: For hubs with an interference (shrink) fit or hubs with internal splines, please contact Lovejoy Technical Support for additional information regarding mounting hubs on equipment shafts.

3. It is necessary to clean the exposed surfaces of all the coupling components including the hubs, elements, and hardware. This will remove any protective coatings applied at the factory. All coupling parts and equipment components must be clean and free of any foreign materials prior to attempting assembly or installation. Care should be taken to ensure any cleaning solvents used do not contain hydrocarbons that could be harmful to the rubber element.

Warning! *DO NOT remove the metal band from around the rubber element until the element is completely bolted in place. (See Step 10)*

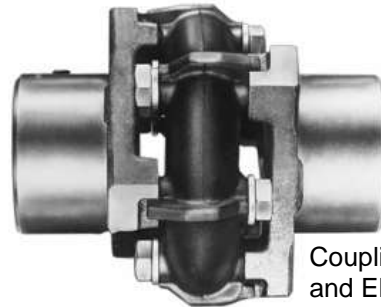

SAGA Style Coupling with Hubs and Element

4. Mount the hubs on the engine/motor and equipment shafts, ensuring the hubs and keys are flush with the end of the shafts. The lengths of the keys should be equivalent in length or slightly longer than the length of the bore through the hub. Secure the hubs and keys in place by tightening the set screws using a calibrated torque wrench and the torque values listed in Table 1.

5. Mount the rubber element on one of the hubs with the element guide extensions resting in the cutouts found on the outside edges of the hub flange (see figure 1). Insert the supplied bolts with a lock washer through the element and start threading the bolts into the hub. Only tighten finger tight at this time. It will help when tightening these bolts to have a small amount of non hydrocarbon based lubricant, such as petroleum jelly, under the head to serve as lubrication when tightening. This will assist in preventing the metal inserts in the rubber element from twisting.



Warning! *If using an adhesive on the bolt threads, DO NOT use an anaerobic adhesive such as Loctite®, Omnifit®, etc. Anaerobic adhesives will attack the bonds between the metallic inserts and rubber element causing the coupling to fail prematurely.*

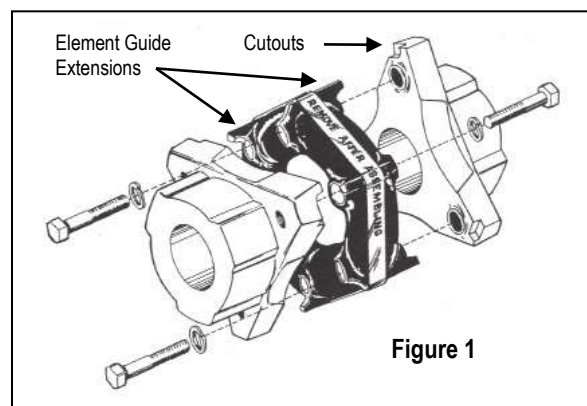

Figure 1

6. Position the equipment using the recommended shaft separation found in Table 1. Use an industry approved method for aligning equipment and equipment shafts. The coupling can accommodate up to 3° angular misalignment and 0.060" parallel misalignment; however when installing this coupling it is recommended that this coupling is installed using no more than 20% of the allowable misalignment. This will ensure the coupling can accommodate inherent misalignment that occurs as a result of foundations settling, equipment movement, and wear.

7. With the equipment secure in the desired position, ensure the rubber element guide extensions are located in the cutout locations in the opposing hub (see figure 1). Insert the remaining bolts as instructed in Step 4 and tighten finger tight.

8. Recheck equipment alignment and ensure the shaft alignment is within the allowable amount. There should be little or no axial pressure on the rubber element when the bolts are tightened.

9. Partially tighten the bolts using a crisscross pattern switching back and forth between sides. Repeat this step getting slightly tighter each time around the pattern. The final tightening pass for these bolts should be completed using a calibrated torque wrench and the torque values listed in Table 2.

10. With the bolts tightened, the band around the rubber element can now be removed. This band will be tight and care should be used to avoid personal injury or damage to the element when removing this band. Once this band is removed, it cannot be reinstalled. If this coupling needs to be removed from this equipment for any reason, prior to removing the bolts, the element will need to be compressed using a large hose clamp. If the element is not compressed prior to removal, the element will need to be returned to Lovejoy to have a new band installed.

See the Lovejoy Power Transmission Catalog for maximum speed and torque limitations when operating this coupling. Care must be used to ensure these limits are not exceeded at any time.

Coupling Size	Set Screw (all are Cup Pt) Size *	Required Tightening Torque for the Set Screws		Spline L-LOC Set Screws Torque	Required Shaft Separation
		ft-lbs	Nm		
S-11	5/16-18 UNC-2B	13	17	Contact Lovejoy Technical Support	1.56"
	M6 x 6mm	3.6	5		
	M8 x 10mm	13	17		
S-13	5/16-18 UNC-2B	13	17		1.72"
	M8 x 8mm	7	10		
	M8 x 12mm	13	17		
S-15	3/8-16 UNC-2B	20	27		1.88"
	M10 x 10mm	15	20		
	M10 x 16mm	25	34		
S-18	1/2-13 UNC-2B	35	47		2.44"
	M12 x 12mm	33	45		
	M12 x 16mm	44	60		
S-22	1/2-13 UNC-2B	35	47	2.69"	
	M12 x 12mm	33	45		
	M12 x 16mm	44	60		
	M12 x 25mm	44	60		
S-26	1/2-13 UNC-2B	35	47	3.12"	
	M12 x 16mm	44	60		
	M12 x 25mm	44	60		
S-30	5/8-11 UNC-2B	90	122	3.62"	
	M16 x 16mm	66	90		
	M16 x 25mm	100	135		
	M16 x 35mm	110	150		
S-34	5/8-11 UNC-2B	90	122	3.98"	
	M16 x 16mm	66	90		
	M16 x 25mm	100	135		
	M16 x 35mm	110	150		

* Set Screw lengths are determined by bore size.

Coupling Size	Qty	Bolts Grade No. 5 Size	Required Tightening Torque for the Bolts			
			Wet non hydrocarbon lubricant		Dry (No Lubricant)	
			ft-lbs	Nm	ft-lbs	Nm
S-11	6	5/16-18 x 1-3/4"	13	18	17	23
S-13	6	3/8-16 x 2"	23	31	30	41
S-15	6	3/8-16 x 2-1/2"	23	31	30	41
S-18	6	1/2-13 x 3"	55	75	75	102
S-22	6	5/8-11 x 3-1/4"	110	149	150	203
S-26	6	3/4-10 x 4"	200	271	260	353
S-30	6	3/4-10 x 4-1/2"	200	271	260	353
S-34	8	3/4-10 x 4-1/2"	200	271	260	353

If there are any additional questions or concerns related to the installation of this SAGA Torsional Coupling, please contact Lovejoy, Inc. Technical Support at the phone number listed below.

Lovejoy, Inc.
World Headquarters
 2655 Wisconsin Avenue
 Downers Grove, IL 60515
 630-852-0500
 630-852-2120 Fax
 info@lovejoy-inc.com



www.lovejoy-inc.com

ISO 9001
 68514489964
 Revision Date: Oct-2019