

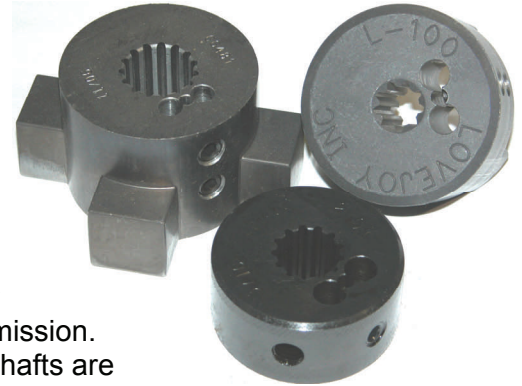

# L-LOC Spline Shaft Clamping Feature

Spline shaft wear, profile distortion, and fretting corrosion all are major concerns for users of hydraulic pumps and other spline shaft applications. Lovejoy has a solution. It's called L-LOC.

It is common knowledge that typical manufacturing tolerances between spline shafts and mating coupling hubs create some unavoidable play or backlash. This backlash is defined as the minor movement between the shaft and hub resulting in wear. This tolerance related movement and wear is often further compounded by misalignment and hammering forces that are common in power transmission. As a result, fretting wear and profile distortion can occur, even when shafts are manufactured with high quality hardened steel using tight tolerances. The results are abnormal stresses on seals, bearings and other engine or pump components, and costly 'down time'. A great deal of money is spent each year on maintenance caused by this premature wear and equipment failure.



The ideal solution to the spline distortion and wear is to eliminate the backlash or clearance related to mating tolerances and assembly misalignment. There are many solutions available, but most are expensive, time consuming, and for the most part, unsuccessful and could cause additional damage.

Lovejoy coupling hubs with the L-LOC spline clamping feature have proven themselves by successfully eliminating the backlash, clearance issues, and damage caused by the hammering effects of vibration, including torsional vibration. The result is longer lasting spline profiles in shafts and couplings and longer periods of time between maintenance visits.

The L-LOC feature is a remarkably simple, yet effective design consisting of a unique 'dog bone' shaped slot that is placed slightly above and parallel to the spline bore. Set screws are fitted perpendicularly into this slot. As the set screws are tightened to a defined torque calculated by Lovejoy's experienced engineering staff, the spline shaft is "wrapped" with a clamping force around the entire spline profile.

The hub becomes firmly locked in place around the spline shaft and the set screws never come in contact with the spline. As a result, users will never see dents, gouges, or burrs on the shaft from mounting the hub and there is no need for hammering the hub on or off the shaft due to tight tolerance. While in use the hub and shaft virtually become a single entity, yet when the set screws are loosened, the L-LOC releases its grip and the hub can be easily removed from the spline shaft.

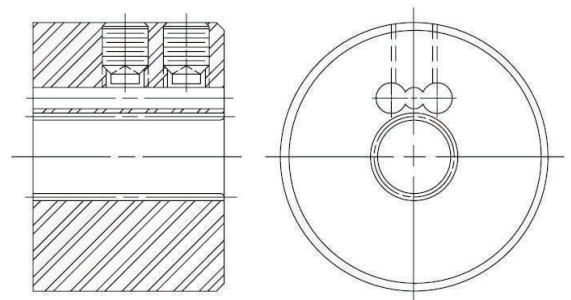

## L-LOC Features:

- Quick and easy assembly and/or removal
- There's reduced stress on equipment components
- Improves effectiveness in connection between shaft and hub
- It eliminates premature spline shaft maintenance or replacement
- Helps reduce equipment noises that would normally be related to couplings