

1.0 INTRODUCTION:

The following document is intended for the explicit use of Lovejoy customers to aid in the installation of Lovejoy power transmission products. The information may be considered privileged and should only be disseminated as an active part of conducting business with Lovejoy, Inc.

Although the coupling may have been properly specified during the design and selection process before the coupling was ordered, operational conditions could possibly have changed prior to installation. Lovejoy, Inc. provides the information and technical support necessary to ensure the appropriate coupling selection was made relative to the product specifications and limitations of Lovejoy's power transmission products. The end user is ultimately responsible for verifying the suitability of the final coupling selection based on the actual service conditions at the time the coupling is installed.

Correct installation and alignment practices will ensure longer coupling life, trouble free operation, and a safer operating environment for the coupling. Please thoroughly review all of the instructions in this document prior to installing this coupling and placing it in operation. Proper safety guidelines and practices should always be followed during every phase of the installation.

This installation document is considered part of the purchased product and should be retained for future reference.

2.0 SAFETY:

Accidents involving rotating equipment may result in loss of life, serious bodily harm, or property damage. The purchaser of this equipment must assure that the equipment is properly assembled, installed, safeguarded, operated, and maintained. This equipment should never be operated at, or subjected to, conditions that exceed manufacturer's specifications.

Consult all applicable Federal, State and local laws and regulations covering the safe operation and maintenance of equipment, including, without limitation, the USDOL-OSHA "Lockout / Tag-out" procedure set forth in 29 CFR 1910.147.

Because of the possible danger to persons or property from accidents which may result from the improper use or unapproved modifications of the product, this product must be installed, maintained and operated in accordance with the procedures, standards, and engineering specifications specified in the product literature. To assure safe operation, this product should be inspected in accordance with the instructions described in this document. Proper guards and any suitable safety equipment or procedures as may be necessary, or as may be specified in safety codes, should be installed by the user. Safety equipment, coupling guards, and shields are not provided by, nor are they the responsibility of Lovejoy, Inc.

Symbols and text format used in this document may contain safety information and will appear similar to the following:



Warning! This symbol indicates safety measures which must be observed to avoid personal injury.

CAUTION! This symbol indicates safety measures which must be observed to avoid damage to coupling.

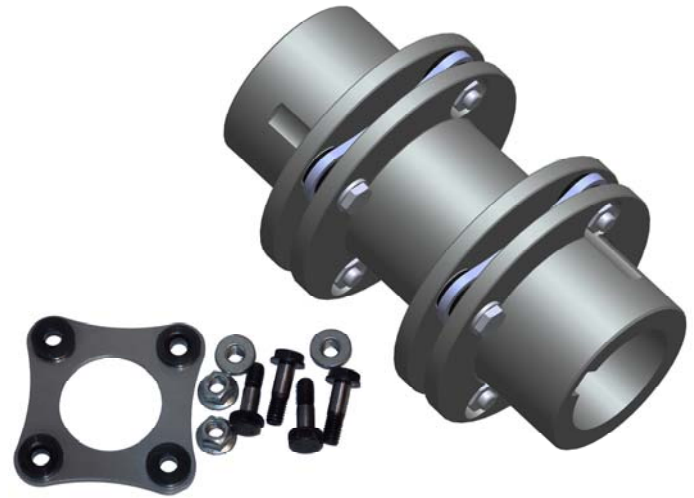

3.0 PRODUCT INSPECTION:

Prior to installation, the coupling should be examined for signs of damage that may have occurred as a result of shipping or handling. Refer to the following chart (Table-1) to ensure all the ordered parts were included with the shipment.

Note: Standard SX Disc Couplings are shipped unassembled.

Table 1: Parts List

Size	Hubs	Spacer	Disc Packs	Hardware	
				Bolts	Lock Nuts
80-4	2	1	2	8	8
90-4	2	1	2	8	8
104-4	2	1	2	8	8

For maximum protection, the coupling and all components should be stored in the original packaging. All parts should be measured prior to installation to ensure correctness of parts to meet the application requirements; such as the hub bore diameter, shaft diameter, shaft separation, bolt lengths, key sizes, etc.



Warning!

Before performing the coupling installation, make sure the machinery is made safe. Disconnect and lock out all power to the equipment. No part of the installation should be performed on moving, non secure, or unstable equipment.

CAUTION!

Lovejoy manufactured the coupling interface based on the equipment and shaft data supplied by the purchaser. Lovejoy is not responsible for inaccurate or incomplete information supplied by the purchaser. It is the purchasers' responsibility to assure that the interface connections between the coupling and the connected equipment are capable of handling the anticipated loads.

4.0 REQUIRED TOOLS:

- Vernier Calipers
- Calibrated Torque Wrench
- Sockets and appropriate open end wrenches
- Alignment Equipment

5.0 COUPLING AND COMPONENT PREPARATION:

5.1 Prior to installation, all exposed surfaces of the coupling and components, including hubs, disc packs, and hardware should be thoroughly cleaned to remove any protective coatings normally applied by Lovejoy at the factory. These coatings are applied as corrosion protection for the coupling surfaces during shipping. All coupling parts, equipment components, shafts, and keyways must be clean and free of any foreign materials prior to attempting assembly or installation. A clean cloth dampened with a nonflammable solvent should be sufficient for this cleaning.

5.2 All sleeves, seals, hub bores, shafts, keys, and keyways should be checked for raised metal, nicks, burrs, dents, gouges, etc., and dressed or repaired accordingly prior to installation.

5.2.1 Prior to removing any existing coupling, establish and record the Distance Between Shaft Ends (BSE) between the driver and driven shafts. Compare this value with the BSE dimension for the Disc Coupling as purchased.

5.2.2 Once all necessary measurements have been taken and all components are confirmed to be correct, remove any existing coupling and dress the shafts of the driver and driven equipment.

5.2.3 If the final shaft separation is the same as the specified BSE for the Lovejoy Disc coupling, then the hubs can be mounted flush with the ends of the driver and driven shafts.

5.2.4 If the final shaft separation is different than the specified BSE of the Lovejoy Disc coupling, then the hubs must be mounted on the driver and driven shafts so that the distance between the hub flanges match the 'BSE' dimension of the coupling as purchased. If this dimension cannot be met, please contact your coupling supplier.

CAUTION! *The amount of hub engagement on the shaft should be 80% of the shaft diameter or greater for an interference fit, 100% or greater for Clearance Fit.*

5.3 Lovejoy machines bores in all Lovejoy disc coupling hubs with 'inch' dimensioned straight bores and keyways to meet the industry accepted **ANSI/AGMA 9002-B04** Standards' tolerance for an interference, or shrink fit bore unless otherwise specified. Tapered and spline bores typically require special consideration.

5.4 Lovejoy machines bores in all Lovejoy disc coupling hubs with 'metric' dimensioned straight bores and keyways to meet the industry accepted **ANSI/AGMA 9112-A04** Standards' tolerance for an interference, or shrink fit bore unless otherwise specified. Tapered and spline bores typically require special consideration.

5.5 For all Lovejoy disc coupling hubs with taper bores and taper bores with keyways, Lovejoy manufactures these hubs with bores using tolerances and specifications as supplied by the customer. Taper bores will be tested with plug gauges usually supplied by the customer or included in the cost of the coupling.

6.0 HUB INSTALLATION (INTERFERENCE FIT):

6.1 Prior to installing any coupling, it is important to make sure the equipment where the coupling is being installed is made safe and no part of this installation will be done on non-secured, unsafe, or moving equipment. Ideally, the equipment should be disconnected from any power source using the Lockout/Tag-out procedures defined by OSHA. Consult with local, State, and Federal laws and regulations covering safe operation and maintenance of equipment.



Warning!

When installing hubs, consult with all applicable Federal, State, and local laws and regulations covering the safe operation and maintenance of equipment, including, without limitation, the USDOL-OSHA "Lockout/Tag-out" procedure set forth in 29 CFR 1910.147.

6.2 Lovejoy disc coupling hubs are shipped with Interference Fit bores unless otherwise specified. Prior to installing the coupling, measure the shaft diameters and the hub bores to ensure proper fits. With interference fits, the hub bore diameters should be slightly less than the shaft diameters and the hubs will need to be heated prior to mounting on the shafts.

Note, the Engineering Data section of the *Lovejoy Power Transmission Products Catalog* on-line contains the actual bore and keyway sizes supplied by Lovejoy for specific shaft sizes. Please visit the Lovejoy website at: <http://www.lovejoy-inc.com>.

6.3 Install the keys in the shaft keyways. Each key should fit snugly in the keyway with no side to side movement. The key should be the same length as the hub to maintain dynamic balance and transmit the maximum torque.

6.4 When mounting hubs that have been machined with an interference fit, there should be a slight clearance between the top of the key and the keyway. Without this clearance, when the hub cools, the keyway will rest on the key creating high stresses in the hub that could cause the hub to fail.

6.5 Heat the hubs and slide them on the shafts with flange end located flush with the end of the shaft. Make sure the hub is heated uniformly to a temperature of at least 350° F (177° C). Steps 6.5.1 through 6.5.4 provide procedures that can be used when heating interference fit hubs.

6.5.1 Oil Bath Heating is usually limited to 350° F. (177° C), or some temperature that is less than the flash point of the oil used. Special handling devices are required to support the hub in the oil bath such as tongs, threaded rods or eye-bolts placed in puller holes, etc. The hubs should not rest on the bottom of the oil bath container and must remain in place for a period of time ample to heat the hub all the way through.



Warning!

If an oil bath is used, the couplings will need to be heated to approximately 350° F (177° C) or more, so the oil must have a flash point above 350° F (177° C).

6.5.2 Induction Heating can be used as long as the temperature rise in the hub is uniform and controlled.

6.5.3 Oven Heating offers definite advantages over oil bath heating. Parts can be heated to higher temperatures, usually 450° F to 600° F (235° C to 315° C). 600° F is the maximum temperature where the steel hub does not go through an annealing process and yet can still be handled with heat resistant gloves. When heating the hubs in an oven, place them on a rack and do not rest the hubs on the oven surface. The hubs should remain in the oven for a sufficient period of time to heat the hub all the way through.

6.5.4 Open Flame Heating is typically not recommended. If the hub is being heated with an oxyacetylene, or blow torch, use an excess acetylene mixture. Mark the hub body at the top, center, and bottom along the length of the hub with heat resistant crayons, one with a 350° F (177° C) melt temperature and another with a 450° F (232° C) melt temperature. The hub should be sitting elevated on refractory bricks oriented to allow the flame to flow through the hub. With a "Blue Flame" or "Rosebud" torch, direct the flame towards the hub bore using constant motion to avoid overheating any single area. Once the heat sensitive crayon marks melt, the hub should be ready for mounting.

**Warning!**

Do not use an open flame in a combustible atmosphere or near combustible materials.

CAUTION!

Do not "spot" heat the hub in single areas or distortion of the hub could occur.

CAUTION!

Do not exceed 600° F (315° C) during the heating process. Excessive heat can soften, or anneal the hub, reducing the strength of the steel thus affecting the performance characteristics of the hub.

CAUTION!

Use extreme care when handling heated hubs to avoid injury to personnel.

6.6 If either hub was manufactured with a clearance, or slip fit bore, slide these hubs onto the appropriate shafts. Align the flanged end of the hub flush with the end of the shaft and key. These hubs will be held in place with set screws.

**Warning!**

Always allow the hubs to cool to ambient (room) temperature prior to continuing with the installation.

7.0 INSTALL SPACER AND DISC PACKS:

7.1 Always allow the hubs to cool to the ambient, or room temperature prior to proceeding with the installation.

7.2 If the equipment is not already in the operating position, move the equipment into position ensuring the measured distance between the shaft ends matches the 'BSE' dimension of the coupling as ordered from the supplier. The shafts should be aligned using an acceptable optical method, preferably laser alignment. When the equipment shafts are aligned and the gap between the shaft ends match the BSE of the coupling as ordered, tighten the equipment anchor bolts to the manufacturer's specified torque.

7.3 Apply a light film of grease to both sides of all the bushings on both disc packs to prevent the bushings from binding and twisting when the lock nuts are tightened. This could cause distortion in the disc packs that could lead to premature disc pack failure.

7.4 Carefully move the spacer into position between the hubs without allowing the spacer to impact either hub. Always maintain support for the spacer until all bolts are in place.

7.5 Slide one disc pack between the flanges of the hub and the spacer. Insert the bolts through the small holes in the hub flange and through the bushings in the disc pack. The lock nuts will be placed on the bolts through the larger holes in the spacer. Hand tighten the lock nuts against the disc pack bushings.

7.6 Insert the bolts through the small holes in the spacer flange and through the bushings in the disc pack. The lock nuts will be placed on the bolts through the larger holes in the hub. Hand tighten the lock nuts against the disc pack bushings.

7.7 Use an open end or box end wrench to prevent the bolts from turning, then with a calibrated torque wrench, tighten the lock nuts on this disc pack using the industry standard procedure for tightening the nuts first to 50%, then 75%, then to the final torque specified in Table-2. Tighten all of the lock nuts on one side of the disc pack before tightening the lock nuts on the second side.

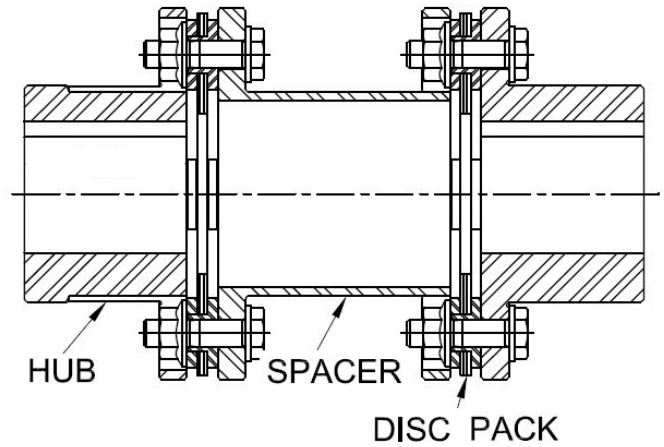

7.8 Repeat steps 7.3 through 7.7 to install the disc pack in the other end of the coupling. If the space between the flange on the second hub and the spacer measures less than the standard PW Width from Table-3, or is too narrow for the disc pack to fit between the flanges, the equipment may need to be repositioned to install this disc pack.

7.9 Measure the gaps between the hubs and spacer on both ends of the coupling. The gaps should match the 'PW', or Pack Width dimension specified in Table-3.

7.10 Inspect the disc packs to ensure there is no waviness or gaps between the layers in the disc pack (see photos below). If the gap between the hub and spacer flange does not match the 'PW', or pack width dimension specified in Table-3, the disc pack could take on a wavy appearance. To correct this, axial adjustments of the equipment may need to be performed. If any of the disc pack bushings rotated while tightening the lock nuts, the layers, or leaves in the unitized disc pack could show signs of bowing, or separating (see photos below). This can be corrected by loosening the lock nuts, then add a slight film of grease between the bushing and lock nut and retighten the lock nuts to the specified torque.



7.11 With a calibrated torque wrench, tighten and recheck all the disc pack bolts at each end of the coupling. See Table-2 for the proper torque to use for tightening the disc pack bolts.

7.12 Again, at both disc pack locations, measure the gap between the hub and spacer flanges at four or more locations around the coupling at each disc pack, preferably the 3:00, 6:00, 9:00, and 12:00 positions and compare these values with the 'PW'/Low value and the PW'/High value in Table-3. If any of the measurements fall outside the low/high range, make adjustments in the equipment alignment before continuing.

7.12 Remove any tooling and material away from the coupling and equipment. Install the coupling guard per OSHA requirements and remove the Lockout / Tagout kit from the power supply. The equipment can then be started up and tested. The coupling and equipment should run smoothly. If vibration is detected it could indicate there is an issue with alignment or other problems possibly related to the motor, coupling, or driven equipment. These issues should be resolved prior to placing this coupling into operation.

8.0 STANDARD COUPLING INSPECTION AND MAINTENANCE:

8.1 A static coupling inspection can be performed with the equipment stopped and made safe per OSHA, or other federal, state, and local government requirements. The coupling should be inspected for any signs of damage, wear, or fatigue that may have occurred during normal operation of the equipment. The coupling should be rotated to facilitate a full 360° inspection. The following steps should be taken:

8.1.1 Inspect all fasteners for signs of damage, wear, or fatigue and make sure all the bolts (and lock nuts) are tightened to the torque specified in Table-2. Replace and retighten the bolts as necessary.

8.1.2 Inspect the disc packs for cracks, separation of the layers or leaves within the disc pack (see Section 7.10) and any other abnormalities that may offer evidence of fatigue or wear. The disc packs, bolts, and locknuts should be replaced if necessary.

8.1.3 Inspect the disc pack bushings (4 per disc pack) for signs of any cracks or breaks and replace the complete disc pack if necessary. Replace the bolts and locknuts anytime replacement disc packs are installed. Replacement disc packs kits come with hardware.

8.1.4 Inspect the hubs and spacer for distortion or signs of damage and wear. If necessary, replace these components.

8.2 Dynamic Coupling Inspection can be performed while the coupling is in operation. The disc packs can be inspected through a protective shield or mesh screen using a strobe light. Use the following steps when performing a dynamic inspection.

8.2.1 If there is vibration present in the system, the cause may not necessarily come from the coupling. There could be balance issues with the driving or driven equipment which could cause damage to the equipment or coupling if left unresolved.

8.2.2 Provide access to viewing each disc pack through a safety shield or mesh screen so that the disc packs can be viewed using a strobe light with the coupling operating under load.

8.2.3 Adjust the strobe light so that each disc pack appears to be stationary, or rotating very slowly. Adjust the strobe on intervals to ensure the inspection can be performed on all the disc pack bushings and disc segments.

8.2.4 Check for cracks, breaks, or looseness in the bushings.

8.2.5 Check each disc pack for any bowing or separation of the layers or leaves in the disc pack (see section 7.10).

8.2.6 Check each disc pack for waviness or distortion (see section 7.10) that could indicate misalignment or improper 'PW' spacing.

8.2.7 Check both disc packs for any broken, frayed, or cracked layers or leaves. Specifically look for broken leaves on the outer layers of each disc pack next to the bushings. This is the symptom for the early stages of a normal disc fatigue failure caused by misalignment.

8.3 If any of the conditions specified in sections 8.1 and 8.2 exist, the cause should be resolved prior to placing the equipment back in operation. If the equipment needs to be moved or disc packs replaced, always recheck the equipment alignment before operating.

9.0 DISC PACK REPLACEMENT:

9.1 Remove the disc pack by first removing the lock nuts and bolts that hold the disc pack in place. Discard these fasteners and use the new fasteners supplied with the replacement disc pack kit when the new disc pack is installed. If the disc pack does not drop out from between the hub and spacer flanges, one of the pieces of equipment may need to be moved.

9.2 Position the replacement disc pack between the hub and spacer flanges. Insert the disc pack bolts through the small holes in the hub flange, then through the bushings in the disc pack.

9.3 Place the lock nuts on the bolts through the large holes in the spacer flange and tighten until snug against the disc pack bushing. If one of the pieces of equipment needs to be moved back into place, do not tighten the lock nuts with the torque wrench until the equipment is in position and aligned.

9.4 Install the remaining disc pack bolts through the flange on the spacer. Hand tighten the lock nuts through the clearance holes in the hub until they contact the disc pack bushings.

9.5 Tighten the lock nuts on the disc pack bolts. Use an open or box end wrench to hold the bolt heads while tightening the nuts with a calibrated torque wrench. The socket will need to fit inside the clearance holes in the flanges. Tighten the lock nuts using the industry standard procedure of first tightening the nuts to 50%, then 75%, then the full amount of the torque specified in Table-2. Tighten all the nuts on one side of the disc pack prior to tightening the second side.

9.6 Repeat steps 9.1 through 9.5 for the second disc pack.

9.7 If equipment was moved, check alignment first using the optical, or laser method, then measure the disc pack gap width at four or more locations around the coupling, preferably at the 3:00, 6:00, 9:00, and 12:00 positions compare these values with the 'PW'/Low value and the PW'/High value in Table-3. If any of the measurements fall outside the high/low range, make adjustments in the equipment alignment before continuing.

9.8 Remove any tooling and material away from the shafting and coupling. Install the coupling guard per OSHA requirements and remove the Lockout / Tagout kit from the power supply. The equipment can then be started up and tested. The coupling and equipment should run smoothly. If vibration is detected it could indicate there is an issue with alignment or other problems possibly related to the motor, coupling, or driven equipment. These issues should be resolved prior to placing this coupling into operation.

Table 2: Bolt Tightening Torque

Size	Disc Pack Bolt Tightening Torque	
	in-lbs	Nm
80-4	115	13
90-4	115	13
104-4	310	35



Table 3: Allowable Misalignment

Size	Disk Pack Width (PW) - Gap								Misalignment				
	Standard Pack Width (PW)				PW +/- Dimensions				Axial $\pm\Delta Ka$		Angular Max Degree	Parallel Max	
	PW		Tolerance +/-		Low		High						
in	mm	in	mm	in	mm	in	mm	in	mm	inch	mm		
80-4	0.262	6.65	0.003	0.08	0.259	6.6	0.265	6.7	0.030	0.8	0.7°	Spacer Length x 0.008"	Spacer Length x 0.2mm
90-4	0.291	7.40	0.004	0.11	0.287	7.3	0.295	7.5	0.040	1.0			
104-4	0.358	9.10	0.005	0.13	0.353	8.9	0.363	9.2	0.050	1.3			

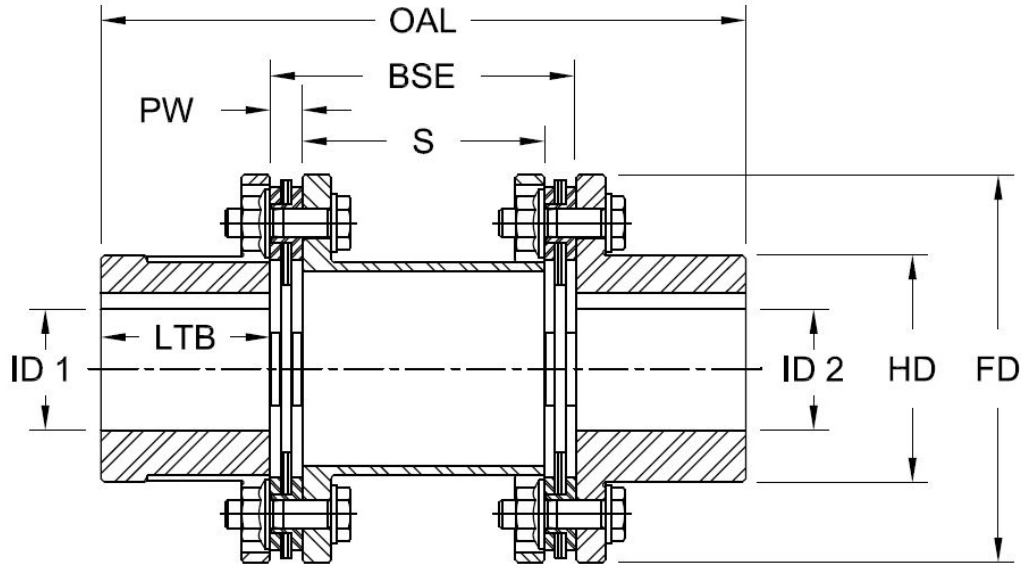

Table 4: Dimensional Data

Size	OAL		BSE Standard		S		ID1 - ID2 Max Bore		'PW' Pack Width		LTB		FD		HD	
	in	mm	in	mm	in	mm	in	mm	in	mm	in	mm	in	mm	in	mm
80-4	5.26	134	2.50	63.5	1.98	50	1.31	34	0.262	6.65	1.38	35	3.15	80	1.85	47
90-4	5.77	147	2.63	67.0	2.05	52	1.56	41	0.291	7.40	1.57	40	3.54	90	2.24	57
104-4	6.74	171	3.12	79.0	2.40	61	1.75	45	0.358	9.10	1.81	46	4.09	104	2.48	63

Table 5: Performance Data

Size	Torque				Max Speed Unbal RPM	ID1 - ID2 Max Bore		Weight	
	Nominal		Peak			in	mm	lb	kg
	in-lb	Nm	in-lb	Nm					
80-4	885	100	1,590	180	8,300	1.31	34	2.89	1.31
90-4	1,590	180	2,830	320	7,500	1.56	41	4.06	1.84
104-4	2,210	250	3,980	450	6,300	1.75	45	6.47	2.93

Lovejoy, Inc.
 World Headquarters
 2655 Wisconsin Avenue
 Downers Grove, IL 60515
 630-852-0500
 630-852-2120 Fax
 info@lovejoy-inc.com



www.lovejoy-inc.com

ISO 9001:2008 Certified

Version Date: 28-February-2013