



# Disc Couplings SXC Close Coupled Spacer Style (6-Bolt) Installation Guide

## 1.0 INTRODUCTION:

The following document is intended for the explicit use of Lovejoy customers to aid in the installation of Lovejoy power transmission products. The information may be considered privileged and should only be disseminated as an active part of conducting business with Lovejoy, Inc.

Although the coupling may have been properly specified during the design and selection process before the coupling was ordered, operational conditions could possibly have changed prior to installation. Lovejoy, Inc. provides the information and technical support necessary to ensure the appropriate coupling selection was made relative to the product specifications and limitations of Lovejoy's power transmission products. The end user is ultimately responsible for verifying the suitability of the final coupling selection based on the actual service conditions at the time the coupling is installed.

Correct installation and alignment practices will ensure longer coupling life, trouble free operation, and a safer operating environment for the coupling. Please thoroughly review all of the instructions in this document prior to installing this coupling and placing it in operation. Proper safety guidelines and practices should always be followed during every phase of the installation.

This installation document is considered part of the purchased product and should be retained for future reference.

## 2.0 SAFETY:

Accidents involving rotating equipment may result in loss of life, serious bodily harm, or property damage. The purchaser of this equipment must assure that the equipment is properly assembled, installed, safeguarded, operated, and maintained. This equipment should never be operated at, or subjected to, conditions that exceed manufacturer's specifications.

Consult all applicable Federal, State and local laws and regulations covering the safe operation and maintenance of equipment, including, without limitation, the USDOL-OSHA "Lockout / Tag-out" procedure set forth in 29 CFR 1910.147.

Because of the possible danger to persons or property from accidents which may result from the improper use or unapproved modifications of the product, this product must be installed, maintained and operated in accordance with the procedures, standards, and engineering specifications specified in the product literature. To assure safe operation, this product should be inspected in accordance with the instructions described in this document. Proper guards and any suitable safety equipment or procedures as may be necessary, or as may be specified in safety codes, should be installed by the user. Safety equipment, coupling guards, and shields are not provided by, nor are they the responsibility of Lovejoy, Inc.

Symbols and text format used in this document may contain safety information and will appear similar to the following:

 **Warning!** This symbol indicates safety measures which must be observed to avoid personal injury.

**CAUTION!** This symbol indicates safety measures which must be observed to avoid damage to couplings.



## 3.0 PRODUCT INSPECTION:

Prior to installation, the coupling should be examined for signs of damage that may have occurred as a result of shipping or handling. Refer to the following chart (Table-1) to ensure all the ordered parts were included with the shipment.

**Note: Standard SXC Disc Couplings are shipped unassembled.**

**Table 1 - Components**

Size	Hubs	Spacer	Disc Pack Kit		
			Disc Packs	Bolts	Lock Nuts
SXC 90-6	2	1	2	12	12
SXC 110-6	2	1	2	12	12
SXC 132-6	2	1	2	12	12
SXC 158-6	2	1	2	12	12
SXC 185-6	2	1	2	12	12
SXC 202-6	2	1	2	12	12
SXC 228-6	2	1	2	12	12
SXC 255-6	2	1	2	12	12
SXC 278-6	2	1	2	12	12
SXC 302-6	2	1	2	12	12
SXC 325-6	2	1	2	12	12
SXC 345-6	2	1	2	12	12
SXC 380-6	2	1	2	12	12
SXC 410-6	2	1	2	12	12
SXC 440-6	2	1	2	12	12

For maximum protection, the coupling and all components should be stored in the original packaging. All parts should be measured prior to installation to ensure correctness of parts to meet the application requirements; such as the hub bore diameter, shaft diameter, shaft separation, bolt lengths, key sizes, etc.

 **Warning!** Before performing the coupling installation, make sure the machinery is made safe. Disconnect and lock out all power to the equipment. No part of the installation should be performed on moving, non secure, or unstable equipment.

**CAUTION!** Lovejoy manufactured the coupling interface based on the equipment and shaft data supplied by the purchaser. Lovejoy is not responsible for inaccurate or incomplete information supplied by the purchaser.

It is the purchasers' responsibility to assure that the interface connections between the coupling and the connected equipment are capable of handling the anticipated loads.

#### 4.0 REQUIRED TOOLS:

- Vernier Calipers
- Calibrated Torque Wrench
- Sockets and appropriate open end wrenches
- Alignment Equipment
- Appropriate hoist or lifting equipment

#### 5.0 COUPLING AND COMPONENT PREPARATION:

**5.1 Prior to installation, all exposed surfaces of the coupling and components**, including hubs, disc packs, and hardware should be thoroughly cleaned to remove any protective coatings normally applied by Lovejoy at the factory. These coatings are applied as corrosion protection for the coupling surfaces during shipping. All coupling parts, equipment components, shafts, and keyways must be clean and free of any foreign materials prior to attempting assembly or installation. A clean cloth dampened with a nonflammable solvent should be sufficient for this cleaning.

**5.2 All sleeves, seals, hub bores, shafts, keys, and keyways** should be checked for raised metal, nicks, burrs, dents, gouges, etc., and dressed or repaired accordingly prior to installation.

**5.2.1 Prior to removing any existing coupling**, establish and record the Distance Between Shaft Ends (BSE) between the driver and driven shafts. Compare this value with the BSE dimension for the Lovejoy disc coupling in Table-4 to verify the fit of this coupling. The BSE value of the coupling is determined by the disc pack width.

**5.2.2 Once all necessary measurements have been taken** and all components are confirmed to be correct, remove any existing coupling and dress the shafts of the driver and driven equipment.

**5.2.3 If the final shaft separation is the same as the specified BSE** for the Lovejoy Disc coupling, then the hubs can be mounted flush with the ends of the driver and driven shafts.

**5.2.4 If the final shaft separation is different than the specified BSE** of the Lovejoy Disc coupling, then the hubs must be mounted on the driver and driven shafts so that the distance between the hub faces match the 'BSE' dimension specified in Table-3.

**CAUTION!** *The amount of hub engagement on the shaft should be 80% of the shaft diameter or greater for an interference fit.*

**5.3 Lovejoy machines bores in all Lovejoy disc coupling hubs** with 'inch' dimensioned straight bores and keyways to meet the industry accepted **ANSI/AGMA 9002-B04** Standards' tolerance for an interference, or shrink fit bore unless otherwise specified. Tapered and spline bores typically require special consideration.

**5.4 Lovejoy machines bores in all Lovejoy disc coupling hubs** with 'metric' dimensioned straight bores and keyways to meet the industry accepted **ANSI/AGMA 9112-A04** Standards' tolerance for an interference, or shrink fit bore unless otherwise specified. Tapered and spline bores typically require special consideration.

**5.5 For all Lovejoy disc coupling hubs with taper bores and taper bores with keyways**, Lovejoy manufactures these hubs with bores using tolerances and specifications as supplied by the customer. Taper bores will be tested with plug gauges usually supplied by the customer or included in the cost of the coupling.

#### 6.0 HUB INSTALLATION (INTERFERENCE FIT):

**6.1 Prior to installing any coupling**, it is important to make sure the equipment where the coupling is being installed is made safe and no part of this installation will be done on non-secured, unsafe, or moving equipment. Ideally, the equipment should be disconnected from any power source using the Lockout/Tag-out procedures defined by OSHA. Consult with local, State, and Federal laws and regulations covering safe operation and maintenance of equipment.



**Warning!** *When installing hubs, consult with all applicable Federal, State, and local laws and regulations covering the safe operation and maintenance of equipment, including, without limitation, the USDOL-OSHA "Lockout/Tag-out" procedure set forth in 29 CFR 1910.147.*

**6.2 Lovejoy disc coupling hubs** are shipped with Interference Fit bores unless otherwise specified. Prior to installing the coupling, measure the shaft diameters and the hub bores to ensure proper fits. With interference fits, the hub bore diameters should be slightly less than the shaft diameters and the hubs will need to be heated prior to mounting on the shafts. The hubs must be oriented with the flange end mounted first away from the end of the shaft.

Note, the Engineering Data section of the *Lovejoy Power Transmission Products Catalog* on-line contains the actual bore and keyway sizes supplied by Lovejoy for specific shaft sizes. Please visit the Lovejoy website at: <http://www.lovejoy-inc.com>.

**6.3 Install the key into the shaft keyway.** The key should fit snugly with no side to side movement. The key should be the same length as the hub to maintain dynamic balance and transmit the maximum torque.

**6.4 When mounting hubs that have been machined with an interference fit**, there should be a slight clearance between the top of the key and the keyway. Without this clearance, when the hub cools, the keyway will rest on the key creating high stresses in the hub that could cause the hub to fail.

**6.5 Heat the hubs** and slide them on the shafts with small end of the hub located flush with the end of the shaft. Make sure the hub is heated uniformly to a temperature of at least 350° F (177° C). Steps 6.5.1 through 6.5.4 provide procedures that can be used when heating interference fit hubs.

**6.5.1 Oil Bath Heating** is usually limited to 350° F. (177° C), or some temperature that is less than the flash point of the oil used. Special handling devices are required to support the hub in the oil bath such as tongs, threaded rods or eye-bolts placed in puller holes, etc. The hubs should not rest on the bottom of the oil bath container and must remain in place for a period of time ample to heat the hub all the way through.



**Warning!** *If an oil bath is used, the couplings will need to be heated to approximately 350° F (177° C) or more, so the oil must have a flash point above 350° F (177° C).*

**6.4.2 Induction Heating** can be used as long as the temperature rise in the hub is uniform and controlled.

**6.4.3 Oven Heating** offers definite advantages over oil bath heating. Parts can be heated to higher temperatures, usually 450° F to 600° F (235° C to 315° C). 600° F is the maximum temperature where the steel hub does not go through an annealing process and yet can still be handled with heat resistant gloves. When heating the hubs in an oven, place them on a rack and do not rest the hubs on the oven surface. The hubs should remain in the oven for a sufficient period of time to heat the hub all the way through.

**6.4.4 Open Flame Heating** is typically not recommended. If the hub is being heated with an oxyacetylene, or blow torch, use an excess acetylene mixture. Mark the hub body at the top, center, and bottom along the length of the hub with heat resistant crayons, one with a 350° F (177° C) melt temperature and another with a 450° F (232° C) melt temperature. The hub should be sitting elevated on refractory bricks oriented to allow the flame to flow through the hub. With a “Blue Flame” or “Rosebud” torch, direct the flame towards the hub bore using constant motion to avoid overheating any single area. Once the heat sensitive crayon marks melt, the hub should be ready for mounting.

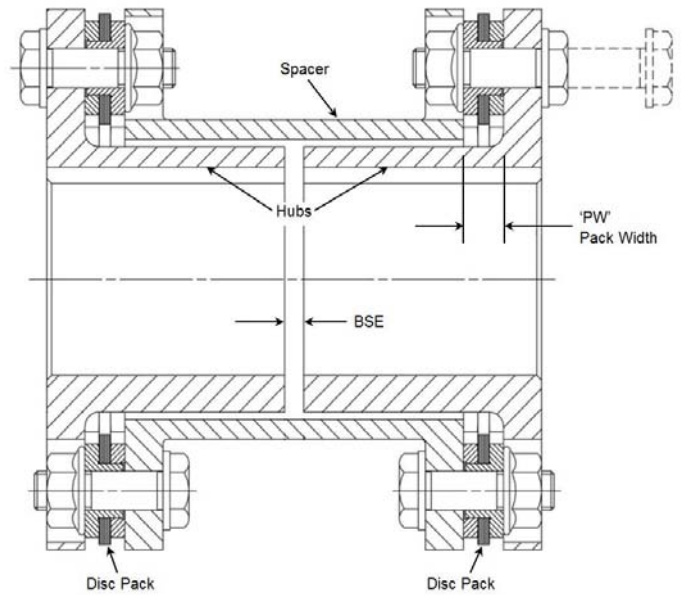

**7.5 Position the spacer over the end of one hub** using care not to impact the spacer flange against the hub, disc pack, or bolts. The large clearance holes on the flange should fit easily over the locknuts holding the disc pack to the hub. If one hub is going to be turned outward for this installation, the spacer should first be mounted on the hub that will be located inside the spacer.

**7.6 Insert the bolts through the small holes** in the spacer flange and through the bushings in the disc pack. The lock nuts will be placed on the bolts through the larger holes in the hub.

**7.7 With an open end or box end wrench holding the bolts**, use a calibrated torque wrench and tighten the nuts on this disc pack using the industry standard procedure for tightening the nuts first to 50%, then 75%, then to the final torque specified in Table-2.

**7.8 Move equipment to operating position**, inserting the second hub inside the spacer (unless hub is facing out) making sure not to impact the spacer flange against the hub, disc pack, or bolts. You will not be able to measure the BSE, or shaft separation, but the gap width between the hub and spacer flanges should match the Pack Width, or 'PW' dimensions in Table 3. The hub will need to be positioned so that the lock nuts holding the disc pack to the first hub will be located in the large clearance holes on the spacer flange.

**7.9 Measure the gap between the hub and spacer flanges** at four or more locations around the coupling at each disc pack. If space permits, suggested locations would be 3:00, 6:00, 9:00, and 12:00. Compare these measurements with the 'PW' Disc Pack Width value specified in Table-3. All measurements must fall within the PW/Low and PW/High values. If the gap for the pack width falls outside this high/low range, make adjustments in the equipment alignment before continuing.

**7.10 Insert the bolts through the small holes** in the spacer flange and through the bushings in the disc pack. The lock nuts will be placed on the bolts through the larger holes in the hub.

**7.11 With an open end or box end wrench holding the bolts**, use a calibrated torque wrench and tighten the nuts on this disc pack using the industry standard procedure for tightening the nuts first to 50%, then 75%, then to the final torque specified in Table-2.

**Warning!** Do not use an open flame in a combustible atmosphere or near combustible materials.

**CAUTION!** Do not “spot” heat the hub in single areas or distortion of the hub could occur.

**CAUTION!** Do not exceed 600° F (315° C) during the heating process. Excessive heat can soften, or anneal the hub, reducing the strength of the steel thus affecting the performance characteristics of the hub.

**CAUTION!** Use extreme care when handling heated hubs to avoid injury to personnel.

**6.6 If either of the hubs was manufactured with a clearance, or slip fit bore**, slide these hubs onto the appropriate shafts. Align the small end of the hub flush with the end of the shaft and key. These hubs will be held in place with set screws.

**Warning!** Always allow the hubs to cool to ambient (room) temperature prior to continuing with the installation.

**7.0 INSTALL DISC PACKS:**

**7.1 Always allow the hubs to cool to the ambient**, or room temperature prior to proceeding with the installation.

**7.2 Apply a light film of grease** to both sides of all the bushings on both disc packs to prevent the bushings from binding and twisting when the lock nuts are tightened. This could cause distortion in the disc packs that could lead to premature disc pack failure.

**7.3 Slide one disc pack over each hub and against the hub flange.** This is only for hubs that will be turned inward. Insert the bolts through the small holes in the hub flange and through the bushings in the disc pack. Hand tighten locknuts on each bolt.

**7.4 With an open end or box end wrench holding the bolts**, use a calibrated torque wrench and tighten the lock nuts on both disc packs using the industry standard procedure for tightening the nuts first to 50%, then 75%, then to the final torque specified in Table-2.

Lovejoy, Inc.  
World Headquarters  
2655 Wisconsin Avenue  
Downers Grove, IL 60515  
630-852-0500  
630-852-2120 Fax  
info@lovejoy-inc.com



[www.lovejoy-inc.com](http://www.lovejoy-inc.com)

ISO 9001:2008 Certified

Version Date: 28-Januarv-2013

**7.12 Inspect each disc pack** to ensure there is no waviness or gaps between the layers in the disc pack. If the gap between the hubs does not match the pack width from Table-3, the disc pack could take on a wavy appearance. To correct this, an axial adjustment will need to be done, likely by moving one or both pieces of equipment.

**7.13** If any of the bushings rotated while tightening the lock nuts, the layers, or leaves in the unitized disc pack could show signs of separating. This can be corrected by loosening the lock nuts, add a slight amount of grease between the bushing and lock nut, then retighten.

**7.14 Remove any tooling and material** away from the shafting and coupling. Install the coupling guard per OSHA requirements and remove the Lockout / Tagout kit from the power supply. The equipment can then be started up and tested. The coupling and equipment should run smoothly. If vibration is detected it could indicate there is an issue with alignment or other problems possibly related to the motor, coupling, or driven equipment. These issues should be resolved prior to placing this coupling into operation.



## 8.0 STANDARD COUPLING INSPECTION AND MAINTENANCE:

**8.1 A static coupling inspection** should be performed with the equipment stopped and made safe per OSHA, or other federal, state and local government requirements. The coupling should be inspected for any signs of damage, wear, or fatigue that may have occurred during normal operation of the equipment. The coupling should be rotated to facilitate a full 360° inspection. The following steps should be taken:

**8.1.1 Inspect all fasteners** for signs of damage, wear, or fatigue and make sure all the bolts (and lock nuts) are tightened to torque specified in Table-2. Replace and retighten the bolts as necessary.

**8.1.2 Inspect the disc packs** for cracks, separation of the layers or leaves within the disc pack (see sections 7.12 and 7.13) and any other abnormalities that may be evidence of fatigue or wear. The disc packs should be replaced if necessary.

**8.1.3 Inspect the disc pack bushings** (6 or 8 per disc pack) for signs of any cracks or breaks and replace the complete disc pack if necessary. Replace the bolts and locknuts anytime replacement disc packs are installed. Replacement disc pack kits come with hardware.

**8.1.4 Inspect the hubs and spacer** for distortion or signs of damage or wear. If necessary, replace these components.

**8.2 Dynamic Coupling Inspection** can be performed while the coupling is in operation. The disc packs can be inspected through a protective shield or mesh screen using a strobe light. Use the following steps when performing a dynamic inspection.

**8.2.1 If there is vibration present in the system**, the cause may not necessarily come from the coupling. There could be balance issues with the driving or driven equipment which could cause damage to the equipment and the coupling if left unresolved.

**8.2.2 Adjust the strobe light** so that each disc pack appears to be stationary, or rotating very slowly. Adjust the strobe on intervals to ensure the inspections can be performed on all the disc pack bushings and disc segments.

**8.2.3 Check for cracks**, breaks, or looseness in the bushings.

**8.2.4 Check the disc pack for waviness** or any distortion (see sections 7.12 and 7.13) that could indicate misalignment or improper 'PW' spacing.

**8.2.5 Check the disc pack for any bowing or separation** of the layers or leaves in the disc pack (see sections 7.12 and 7.13).

**8.2.6 Check the disc pack for any broken**, frayed, or cracked layers or leaves. Specifically look for broken leaves on the outer layers of each disc pack next to the bushings. This is an early stage of a normal disc fatigue failure caused by misalignment.

**8.3 If any of the conditions specified** in sections 8.1 and 8.2 exist, the cause should be resolved prior to placing the equipment back in operation. If the equipment needs to be moved or disc packs replaced, always recheck the equipment alignment before operating.

## 9.0 DISC PACK REPLACEMENT:

**9.1 When replacing disc packs**, consider replacing both disc packs while the coupling is disassembled.

**9.2 Remove the bolts and locknuts that connect the disc pack to the spacer** on the end of the coupling where the equipment will be moved. These fasteners should be discarded and replaced with the fasteners supplied with the new disc pack kit.

**9.3 Carefully move the equipment** so that the hub slides out of the coupling spacer without impacting against the sides of the spacer.

**9.4 While supporting the spacer**, remove the bolts and locknuts that connect the other end of the spacer to the disc pack on the hub that is on the equipment that was not moved. These fasteners should be discarded and replaced with the fasteners supplied with the new disc pack kit.

**9.5 Remove the remaining bolts and locknuts** that hold the disc pack to the hubs. Again, these fasteners should be discarded and replaced with the fasteners supplied with the new disc pack kit.

**9.6 Install the new disc packs** using the steps listed in sections 7.2 through 7.14

**9.7 Since the equipment was moved**, recheck alignment first using the optical, or laser method, then at four or more locations around the coupling, preferably at the 3:00, 6:00, 9:00, and 12:00 positions and compare these values with the 'PW'/Low value and the PW'/High value in Table-3. If any of the measurements fall outside this high/low range, make adjustments in the equipment alignment before continuing.

**9.8 Remove any tooling and material** away from the shafting and coupling. Install the coupling guard per OSHA requirements and remove the Lockout / Tagout kit from the power supply. The equipment can then be started up and tested. The coupling and equipment should run smoothly. If vibration is detected it could indicate there is an issue with alignment or other problems possibly related to the motor, coupling, or driven equipment. These issues should be resolved prior to placing this coupling into operation.

**Table 2 - Lovejoy Disc Pack Bolts & Locknuts**

Size	Socket Size		Torque Wrench	Clearance Hole		Bolt Torque			
	Bolt Size mm	Nut Size mm		Drive Size in	Diameter in	Diameter mm	Lubricated Threads		Dry Threads
			ft-lbs				Nm	ft-lbs	Nm
SXC 90-6	10	10	1/4	0.63	16	8	11	10	14
SXC 110-6	13	13	3/8	0.827	21	18	24	22	30
SXC 132-6	13	13	3/8	0.827	21	18	24	22	30
SXC 158-6	17	15	3/8	1.024	26	35	48	44	60
SXC 185-6	19	18	3/8	1.26	32	59	80	74	100
SXC 202-6	22	21	1/2	1.378	35	89	120	111	150
SXC 228-6	24	24	1/2	1.457	37	136	184	170	230
SXC 255-6	30	30	3/4	1.772	45	266	360	332	450
SXC 278-6	30	30	3/4	1.811	46	266	360	332	450
SXC 302-6	32	32	3/4	1.968	50	354	480	443	600
SXC 325-6	32	32	3/4	2.047	52	354	480	443	600
SXC 345-6	36	36	3/4	2.205	56	460	624	575	780
SXC 380-6	41	41	1	2.362	60	649	880	811	1100
SXC 410-6	46	46	1	2.677	68	885	1200	1106	1500
SXC 440-6	50	50	1	2.913	74	1180	1600	1475	2000

**Note:** Please be advised that the Clearance Hole Diameter of the coupling may be smaller than the Outside Diameter of some typical size socket. The socket's OD may have to be turned down to 0.76 mm (0.030") smaller than the coupling's clearance hole diameter.

**Table 3 - Allowable Misalignment**

Size	Disk Pack Width (PW) - Gap								Misalignment				
	Standard Pack Width (PW)				PW +/- Dimensions				Axial ±ΔKa		Angular Max Degree	Parallel Max inch mm	
	PW		Tolerance +/-		Low		High						
in	mm	in	mm	in	mm	in	mm	in	mm		inch	mm	
SXC 90-6	0.295	7.5	0.003	0.08	0.292	7.43	0.298	7.58	0.030	0.75	1.5°	Spacer Length x 0.025"	Spacer Length x 0.6mm
SXC 110-6	0.331	8.4	0.004	0.11	0.327	8.30	0.335	8.51	0.039	1.00			
SXC 132-6	0.331	8.4	0.005	0.13	0.326	8.27	0.336	8.53	0.051	1.30			
SXC 158-6	0.441	11.2	0.006	0.16	0.435	11.05	0.447	11.36	0.059	1.50			
SXC 185-6	0.551	14.0	0.007	0.19	0.544	13.82	0.558	14.19	0.071	1.80			
SXC 202-6	0.610	15.5	0.007	0.19	0.603	15.31	0.617	15.69	0.075	1.90	1°	Spacer Length x 0.017"	Spacer Length x 0.4mm
SXC 228-6	0.689	17.5	0.008	0.21	0.681	17.29	0.697	17.71	0.083	2.10			
SXC 255-6	0.807	20.5	0.009	0.24	0.798	20.27	0.816	20.74	0.091	2.30			
SXC 278-6	0.835	21.2	0.010	0.26	0.825	20.94	0.845	21.46	0.102	2.60			
SXC 302-6	0.961	24.4	0.011	0.29	0.950	24.12	0.972	24.69	0.110	2.80			
SXC 325-6	1.024	26.0	0.013	0.33	1.011	25.68	1.037	26.33	0.126	3.20			
SXC 345-6	1.110	28.2	0.014	0.35	1.096	27.86	1.124	28.55	0.134	3.40			
SXC 380-6	1.260	32.0	0.015	0.38	1.245	31.62	1.275	32.38	0.150	3.80			
SXC 410-6	1.307	33.2	0.016	0.41	1.291	32.79	1.323	33.61	0.161	4.10			
SXC 440-6	1.433	36.4	0.017	0.44	1.416	35.96	1.450	36.84	0.173	4.40			

Lovejoy, Inc.  
 World Headquarters  
 2655 Wisconsin Avenue  
 Downers Grove, IL 60515  
 630-852-0500  
 630-852-2120 Fax  
 info@lovejoy-inc.com



[www.lovejoy-inc.com](http://www.lovejoy-inc.com)

ISO 9001:2008 Certified

Version Date: 28-Januarv-2013

**Table 4 - Dimensional Data**

Size	OAL		Spacer		BSE (Shaft Separation)			
	(Over All Length)		Length		Standard Configuration		One Hub Turned Out	
	in	mm	in	mm	in	mm	in	mm
SXC 90-6	3.307	84	2.244	57	0.157	4	1.496	38
SXC 110-6	4.094	104	2.835	72	0.157	4	1.811	46
SXC 132-6	4.882	124	3.583	91	0.157	4	2.205	56
SXC 158-6	5.669	144	4.016	102	0.157	4	2.520	64
SXC 185-6	6.457	164	4.409	112	0.157	4	2.835	72
SXC 202-6	7.362	187	5.039	128	0.276	7	3.268	83
SXC 228-6	8.150	207	5.512	140	0.276	7	3.583	91
SXC 255-6	9.331	237	6.142	156	0.276	7	4.016	102
SXC 278-6	10.197	259	6.969	177	0.354	9	4.488	114
SXC 302-6	10.984	279	7.323	186	0.354	9	4.803	122
SXC 325-6	11.732	298	7.953	202	0.315	8	5.157	131
SXC 345-6	12.520	318	8.425	214	0.315	8	5.472	139
SXC 380-6	13.780	350	9.173	233	0.394	10	6.024	153
SXC 410-6	14.961	380	10.000	254	0.433	11	6.535	166
SXC 440-6	15.787	401	10.315	262	0.433	11	6.811	173

**Table 5 - Maximum Radial Load**

Disc Pack Size	Maximum Radial Load per Disc Pack <sup>1</sup>	
	lbf (Pound-Force) <sup>2</sup>	N (Newton) <sup>2</sup>
<b>6 - Bolt</b>		
90-6	90	420
110-6	99	440
132-6	157	700
158-6	225	1 000
185-6	337	1 500
202-6	427	1 900
228-6	585	2 600
255-6	764	3 400
278-6	967	4 300
302-6	1,236	5 500
325-6	1,439	6 400
345-6	1,686	7 500
380-6	2,113	9 400
410-6	2,630	11 700
440-6	3,240	14500

Disc Pack Size	Maximum Radial Load per Disc Pack <sup>1</sup>	
	lbf (Pound-Force) <sup>2</sup>	N (Newton) <sup>2</sup>
<b>8 - Bolt</b>		
278-8	1,281	5 700
302-8	1,754	7 800
325-8	2,001	8 900
345-8	2,360	10 500
380-8	2,945	13 100
410-8	3,709	16 500
440-8	4,429	19 700
475-8	5,171	23 000
505-8	6,182	27 500

- Notes:**
1. Values are based on the shear force calculated for the minor diameter of the disc pack bolts.
  2. The radial load capacity for stainless steel fasteners is approximately 50% of the values listed for standard hardware.