

INSTALLATION AND MAINTENANCE INSTRUCTIONS

Lovejoy

SIER-BATH

CONTINUOUS SLEEVE FLEXIBLE GEAR COUPLINGS

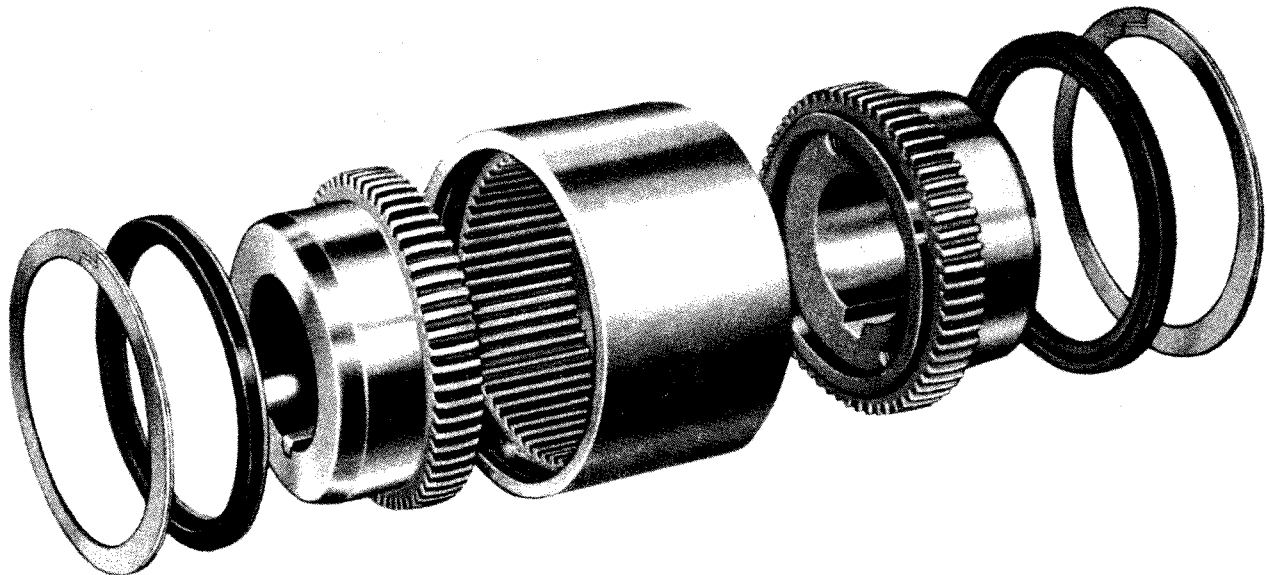

- MORE HORSEPOWER WITH LESS SIZE, WEIGHT
- ASSEMBLED, UNCOUPLED IN SECONDS
- NO WRENCHES OR SPECIAL TOOLS REQUIRED
- SAFE AND SILENT AS SMOOTH SHAFTING

Lovejoy

SIER-BATH®

2655 Wisconsin Ave.
Downers Grove, Illinois 60515-USA
•PHONE - 630-852-0500
•FAX - 630-852-2120

TITLE
INSTALLATION AND
MAINTENANCE INSTRUCTIONS

ITEM NO.
68514460805

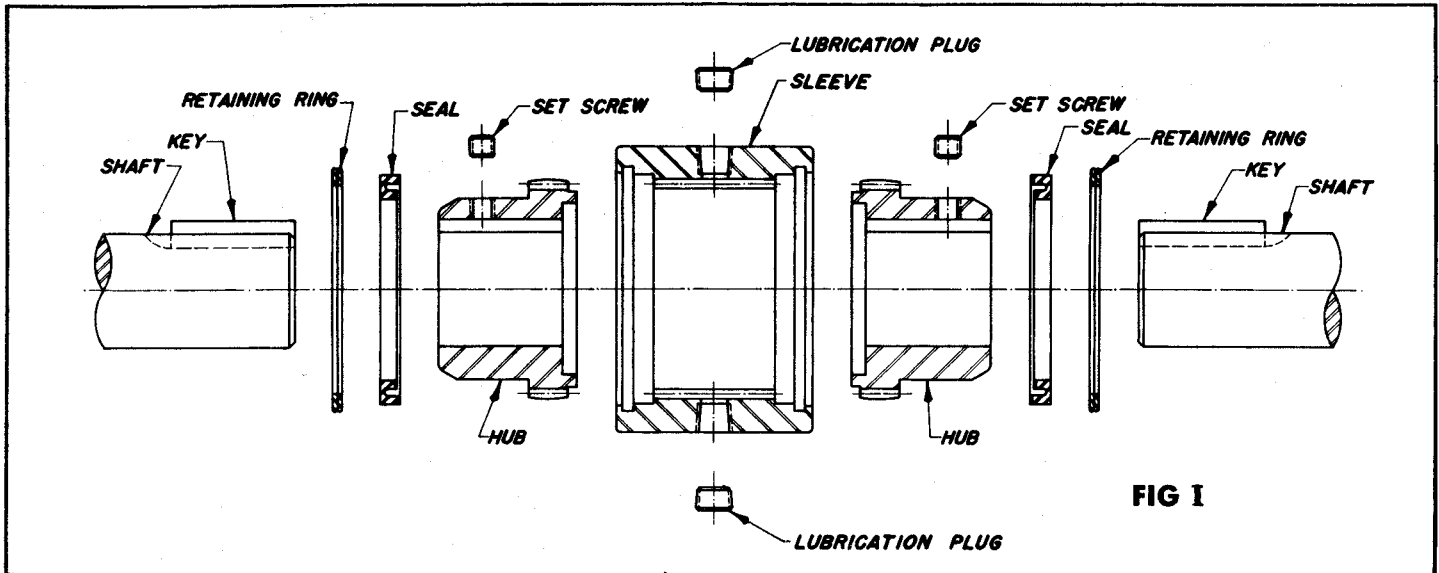

FIG I

FOLLOW THESE SIMPLE STEPS TO CORRECTLY INSTALL THE SIER BATH FLEXIBLE GEAR COUPLING.

- STEP NO. 1** Be sure that all parts are available and are clean.
- STEP NO. 2** Place one (1) snap ring and one (1) seal on each shaft. **IMPORTANT:** Be sure that the groove in the seals face toward the center of the coupling and that the mold mark will be visible after the seals are installed in the coupling.
- STEP NO. 3** Install hubs on shafts as shown in Fig. II or Fig. III.

Note: Hubs may be installed with shaft flush with the counter bore face (Surface "X" Fig. II) or flush with the aligning face (Surface "Y" Fig. III) as long as the proper gap between hubs is maintained (STEP #5).

SHRINK FIT: Shrink fits are recommended for heavy duty or low speed applications. Be sure the key is a snug side fit in the shaft and coupling keyway with clearance on top. Install keys into shafts. Heat hubs uniformly, using hot oil or an oven, to approximately 350°F. Slip hubs on the shafts to the correct location as determined by your installation (see note above).

PRESS FIT: Light press fits may be used for many installations. Unless otherwise specified Sier Bath Couplings are furnished with an interference fit.

SLIDE FIT: Slide fits should only be used in low torque, light duty applications (set screws must be firmly tightened).

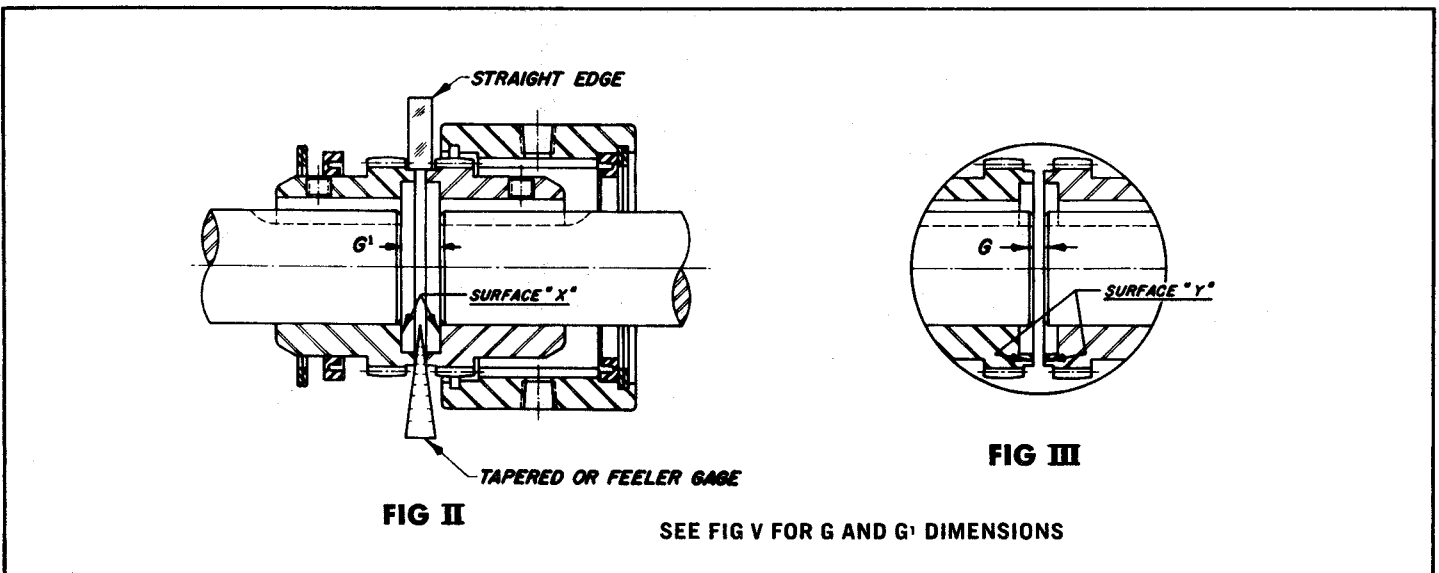
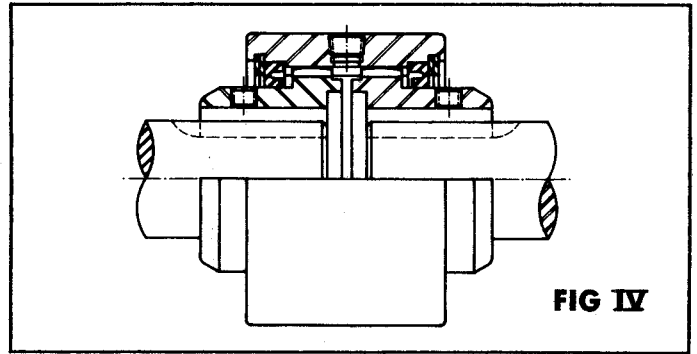

FIG II

FIG III

SEE FIG V FOR G AND G' DIMENSIONS

- STEP NO. 4** Engage gear teeth and slide sleeve over the hub installed on the longest shaft.
- STEP NO. 5** Mount units to be connected in place. Check coupling size (stamped on sleeve) and maintain required spacing G or G' between hubs as shown on Fig. II and Fig. III. Check G Dimension with a tapered or feeler gauge at 90° intervals. Align hubs using a straight edge at 90° points along aligning diameters (aligning should be as close as possible) by shimming or shifting one or both of the connected units.



- STEP NO. 6** Hand pack hub and sleeve teeth with grease, forcing some grease between hub faces G or G' to provide lubricant reservoir. Lightly coat both seals with grease.
- STEP NO. 7** Engage teeth and slide sleeve over hubs to center position. SEE Fig. IV. Press in seals with blunt tool until they are firmly seated against sleeve shoulder. Snap ring grooves should be completely visible. If grooves are not visible, remove sleeve and carefully repeat step # 5 and 6.
- STEP NO. 8** Insert snap rings in grooves, using a winding motion. IMPORTANT: Recheck to insure snap rings are positively seated, and set screws over the keys and the lube plugs are tight.

FIG V

SIZE	GREASE CAPACITY		APPROX. WT. LBS. R. BORE	*DISTANCE BETWEEN SHAFTS	
	WEIGHT	VOLUME		G DIM. FIG. III	G' DIM. FIG. II
C $\frac{7}{8}$	1 oz.	$\frac{1}{8}$ Pt.	5	$\frac{1}{8}$	$\frac{3}{8}$
C1 $\frac{1}{2}$	1 $\frac{1}{2}$ oz.	$\frac{1}{3}$ Pt.	8	$\frac{1}{8}$	$\frac{1}{2}$
C2	2 $\frac{3}{4}$ oz.	$\frac{3}{8}$ Pt.	13	$\frac{1}{8}$	$\frac{1}{2}$
C2 $\frac{1}{2}$	5 oz.	$\frac{3}{4}$ Pt.	20	$\frac{1}{4}$	$\frac{3}{4}$
C3	$\frac{1}{2}$ lbs.	1 $\frac{1}{8}$ Pt.	33	$\frac{1}{4}$	$\frac{3}{4}$
C3 $\frac{1}{2}$	$\frac{3}{4}$ lbs.	1 $\frac{5}{8}$ Pt.	63	$\frac{1}{4}$	$\frac{3}{4}$
C4	1 lbs.	2 $\frac{1}{4}$ Pt.	91	$\frac{1}{4}$	$\frac{3}{4}$
C4 $\frac{1}{2}$	1 $\frac{1}{4}$ lbs.	3 Pt.	126	$\frac{1}{4}$	$\frac{3}{4}$
C5	1 $\frac{1}{2}$ lbs.	3 $\frac{1}{2}$ Pt.	195	$\frac{1}{4}$	$\frac{3}{4}$
C6	2 lbs.	1 $\frac{1}{8}$ Qt.	267	$\frac{1}{4}$	$\frac{3}{4}$
C7	2 $\frac{1}{2}$ lbs.	1 $\frac{3}{8}$ Qt.	320	$\frac{3}{8}$	$\frac{7}{8}$
C9	4 $\frac{1}{2}$ lbs.	2 $\frac{1}{8}$ Qt.	520	$\frac{1}{2}$	1"
C11	4 $\frac{3}{4}$ lbs.	2 $\frac{5}{8}$ Qt.	925	$\frac{1}{2}$	1"
C12	6 $\frac{1}{2}$ lbs.	3 $\frac{5}{8}$ Qt.	1200	$\frac{1}{2}$	1"

*MAY BE ANY DIMENSION BETWEEN G AND G'

MAINTENANCE

Should your Sier Bath Series "C" coupling need to be disassembled for an alignment check, remove one snap ring, slide sleeve off hubs. Seal will be forced out of one end during this operation. Clean out old lubricant and inspect seals and gear teeth. Re-assemble starting at step #7.

To re-lubricate without disassembling coupling, remove both lube plugs and position lube holes at 45° to horizontal. Force grease into top hole until clean grease flows out of opposite hole.

Re-install plugs.

Caution: Always wear safety glasses and use the proper tools when working on machinery.



COUPLING DATA

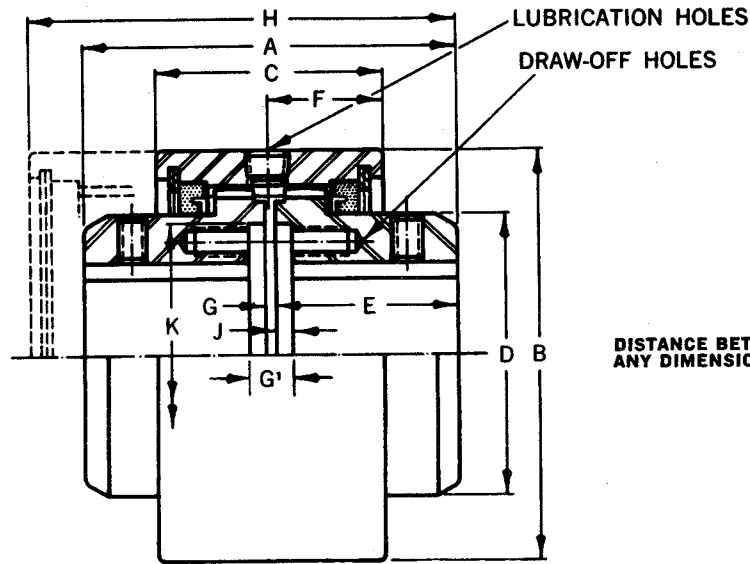

DISTANCE BETWEEN SHAFTS MAY BE ANY DIMENSION BETWEEN G AND G'

SIZE	MAX. BORE	ROUGH BORE	***MAX. SPEED UNBAL.	CAPACITY		DIMENSION IN INCHES											APPROX. WT., LBS. ROUGH BORE
				HP/100 R.P.M.	TORQUE LB. IN.	A	B	C	D	E	F	* Distance Between Shafts		H	J	K	
												G	G'				
C-7/8	1 1/4	7/16	6,000	4	2,520	3 1/8	3 3/16	2	2	1 1/2	1	1/8	3/8	3 3/4	1/8	1 15/16	5
C-1 1/2	1 5/8	5/8	5,000	12	7,560	3 3/4	3 3/4	2 17/32	2 3/8	1 13/16	1 11/64	1/8	1/2	4 19/32	3/16	2 1/4	8
C-2	2 1/8	3/4	4,200	32	20,160	4 1/4	4 3/4	2 9/16	3 1/4	2 1/16	1 9/32	1/8	1/2	4 7/8	3/16	3	13
C-2 1/2	2 5/8	7/8	3,750	48	30,240	4 3/4	5 1/2	3 1/16	3 15/16	2 1/4	1 17/32	1/4	3/4	5 33/32	1/4	3 3/4	20
C-3	3 1/8	1 1/16	3,600	80	50,400	5 1/2	6 5/8	3 3/4	4 3/4	2 5/8	1 7/8	1/4	3/4	6 7/8	1/4	4 3/4	33
C-3 1/2	3 5/8	1 1/4	2,800	140	88,200	8 3/4	7 1/2	4	5 5/8	4 1/4	2	1/4	3/4	9 1/4	1/4	5 1/2	63
C-4	4 1/8	1 3/4	2,400	200	126,000	9	8 3/4	4 5/8	6 1/4	4 3/8	2 5/16	1/4	3/4	9 1/2	1/4	6 1/2	91
C-4 1/2	4 3/4	2 3/8	2,200	292	183,960	10 1/4	9 1/2	4 7/8	7 1/4	5	2 7/16	1/4	3/4	10 3/8	1/4	7 1/4	126
C-5	5 3/4	2 7/8	2,100	430	270,900	12 1/4	10 3/4	5 3/4	8 1/4	6	2 7/8	1/4	3/4	12 1/4	1/4	8 5/8	195
C-6	6 5/8	3 3/8	2,000	600	378,000	13	12 1/4	6 1/2	9 1/2	6 3/8	3 1/4	1/4	3/4	13 3/8	1/4	9 1/4	267
C-7	7 1/2	4 11/16	1,000	950	598,500	14 7/8	14	7 1/2	10 1/2	7 1/4	3 3/4	3/8	7/8	15 3/8	1/4	9 3/4	320
C-9	9 1/2	5 5/8	800	2,000	1,260,000	19	16 1/4	8 1/8	12 5/8	9 1/4	4 1/16	1/2	1	19	1/4	12 1/2	520
C-11	11 1/2	7 3/4	600	3,500	2,205,900	22 1/2	19 1/4	8 1/8	15 5/8	11	4 1/16	1/2	1	22 1/2	1/4	15 1/2	925
C-12	12 1/2	9 3/4	550	4,000	2,520,000	25	20 1/2	8 3/8	16 1/2	12 1/4	4 3/16	1/2	1	25	1/4	16	1,200

Length of one shaft must be equal to or greater than C plus G.

*MAY BE ANY DIMENSION BETWEEN G AND G'

Coupling Grease

LOVEJOY provides high quality, high speed coupling grease for low to high-speed applications. The grease is designed to address the problems that are unique to Gear Coupling applications such as high pressure, high centrifugal force, prolonged work periods and corrosive environments.

Lubrication

Centrifugal separation of the oil and thickener during operation is a basic problem in Gear Coupling applications, especially high speed applications. The higher the operational speed, the greater the amount of separation can be expected, causing the soap properties in the grease to accumulate in the areas where lubrication is required. The soap does not provide adequate lubrication which results in accelerating the coupling wear. The LOVEJOY grease properties are designed to resist centrifugal separation.

Changes in consistency to address different situations is the key to successful lubrication. LOVEJOY grease is manufactured to a No. 1 consistency grade. During prolonged use, the grease will become semi-fluid. When inactive, the grease will thicken, become heavier and will not leak out of the coupling. The ability to change consistency provides successful lubrication across the complete range of requirements.

Contents

The LOVEJOY grease contains ingredients that have been proven to operate successfully in Gear Coupling applications. The grease contains:

- Lithium Soap
- Highly Refined Paraffinic Mineral Oil
- Rust Inhibitors
- Anti-oxidants
- EP/Anti-wear additive

