

Lovejoy / Sier-Bath

"FSL" Slide Type Coupling

Size FSL 2 thru FSL 7

Introduction

Carefully follow the instructions in this manual for optimum performance and trouble free service.

This manual applies to standard "FSL" Slide type couplings. The "FSL" Slide type couplings are recommended for horizontal applications only. For vertical applications please consult with Lovejoy application Engineering.

The "FSL" Slide type coupling is used for applications requiring axial movement between the shaft ends greater than standard. This function must be performed under NO LOAD, STATIC conditions.

Installation & Alignment Instructions

All parts must be clean and free of any foreign materials before attempting assembly, use a non-flammable solvent. All Parts should be examined for any damage during shipping and handling. Measurements should be taken to verify correctness of parts to meet application requirements, such as, hub and shaft fits, shaft separation, etc. Check hubs, shafts and keyways for burrs.

1) Install keys in respective shafts. Keys should fit shaft keyseat with a tight fit on the sides and slight clearance over the key. Coat the shafts with an anti-

Caution: Consult applicable local and national safety codes for proper guarding of rotating coupling. Observe all safety rules when installing or servicing coupling.

Warning: Lockout starting switch of prime mover and remove all external loads from drive before installing or servicing coupling.

TABLE OF CONTENTS

1	Introduction
1	Installation & Alignment Instructions
2	Maintenance
2	Part Identification

galling lubricant. Insure that seals and pipe plugs are in place in the gear sleeve. Lubricate around sleeve gear teeth and seal surface and place over respective shaft **before mounting hubs**. Protect shaft on which sleeve will rest during hub installation.

2) Determine the mounting arrangement of the proper mating hubs as illustrated in figure 1. Heat hubs in either an oil bath or oven until bores are larger than shaft diameter. Mount so that the end of each hub is flush with the end of the shaft as illustrated in figure 1. Allow hubs to cool before proceeding.

WARNING: If an oil bath is used, the oil must have a flash point of 350 °F or higher. Do not rest hubs on the bottom of the container. Do not use an open flame in a combustible atmosphere or near combustible materials.

3) Although the shafts may be perfectly aligned at installation they should be realigned after mounting of coupling. Position equipment in the approximate alignment with the approximate "G" dimension found on Chart 1. Align coupling using the instrument method as described below.

4) Angular Alignment – Using an inside micrometer, **take readings at four points 90° apart**. Adjust machines until all four readings are identical. The difference in maximum and minimum measurements must not exceed the **installation angular** limits specified in chart 1.

5) Parallel Offset Alignment – The dial indicator method is recommended for this procedure. Attach the dial indicator base to one hub and set the dial indicator needle in contact with the outside diameter of opposite hub. Rotate hub on which the indicator is mounted 360°, **taking indicator readings at four points 90° apart**. Adjust machines until all four readings are identical. The difference in maximum and minimum measurements must not exceed the **installation-offset** limits specified in chart 1. Relocate the indicator dial base to the opposite hub and repeat the procedure. Tighten all foundation bolts and repeat step 4 and 5.

Realign coupling if necessary.

Warning: Before installing couplings, make certain that foundations of equipment to be connected meet manufacturer's requirement. Check for "soft foot". The use of stainless steel shims is recommended.

6) Coat hub teeth and body as well as inside of sleeve with coupling grease. Slide the sleeve onto its respective hub, making sure that the gear teeth mesh properly. Apply light dots of oil to one side of the gasket. Install gasket between the sleeve flanges, align the boltholes and press the side with oil against flange. Place Plate into counter bore of sleeve. Move sleeves together, with lube plugs 90° apart. Install bolts and locknuts, tightening alternately and evenly to recommended torque in chart 1. Remove the two lube plugs in each sleeve and fill coupling with the recommended amount of coupling grease indicated in Chart 1. Replace lube plugs and tighten securely.

Maintenance

Following an initial break-in period of about 3 million revolutions (80 hr. @ 600 rpm) it is recommended that the coupling be completely flushed and re-lubricated. Thereafter, a regular relubrication schedule should be maintained. If coupling leaks grease, is exposed to extreme temperatures, excessive moisture or frequent reversals, frequent lubrication may be required. For average industrial operating conditions, relubrication every 12 months should suffice with periodic visual inspections to insure that neither the quality nor the supply (due to leakage) of the lubricate has deteriorated to an unacceptable level.

During relubrication cycle or at least yearly, whichever comes first, the coupling should be disassembled and thoroughly cleaned of all grease. Remove and visually inspect all parts; gear teeth for signs of abnormal stress and wear, the seals and gaskets for any cracks or breaks.

Any parts showing signs of wear or damage should be replaced. These parts are available for purchase by referencing the coupling UPC number, size, type and bolting style. Hub and sleeve should be replaced as half coupling whenever possible.

Check alignment per steps 4 and 5. If maximum operating misalignment values are exceeded, realign the coupling to the recommended installation values found in chart 1.

Lubrication

Adequate lubrication is essential for satisfactory operation. Lovejoy Coupling Grease is specially formulated for coupling applications to increase coupling life while drastically reducing maintenance cycle time. And it's in complete compliance with AGMA 9001 lubrication recommendations.

Unlike bearing or general-purpose grease, coupling grease must withstand the centrifugal forces generated by a spinning coupling. Lovejoy Coupling Grease is designed to resist centrifugal separation, which allows the lubricant to be used for relatively long periods of time.

Other benefits of this product includes; highest pressure and wear protection available, built-in rust and corrosion inhibitors, increased coupling life, reduced maintenance costs, reduced downtime and superior lubrication.

One of the secrets to the success of Lovejoy Coupling Grease is the variable consistency throughout the working cycle of the application. The consistency of our grease changes with the operating conditions. Working of the lubricant under actual service conditions causes the grease to become semi-fluid, functionally splash lubricating the wear surfaces of the coupling. As the grease cools, it returns to the original consistency, thereby preventing leakage.

FIGURE 1

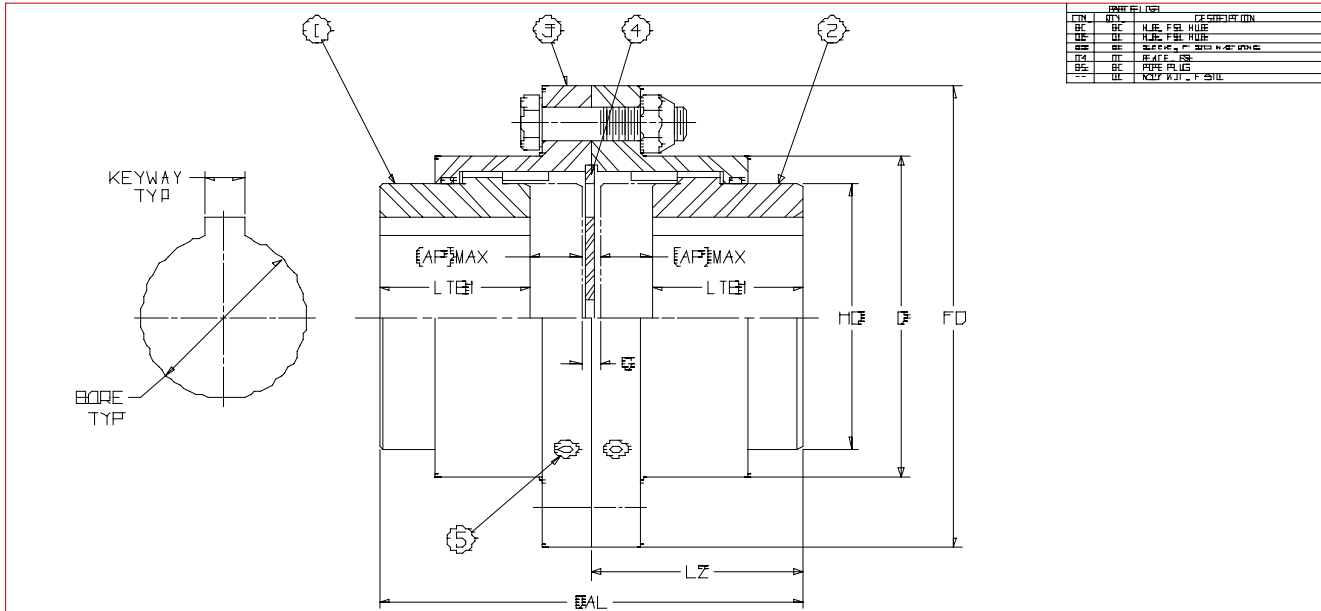

UNIT	IN	MM
IN	1	25.4
MM	0.03937	1

SIZE	WEIGHT (LB)	INERTIA (IN-LB-SEC ²)	REF. J. MAX	MAX. TORQUE (IN-LB)	ROUGH BORE (IN)	BORE MAX (IN)	KEYWAY (IN)	AP MAX (IN)	BAL (IN)	F ₂ (IN)	D _E (IN)	H _{CE} (IN)	L _{TE} (IN)	L _Z (IN)	MIN. MIN (IN)
2E	34	.308	5000	31500	0.84	2.750	5/8 X 5/16	0.78	6.38	7.00	4.91	4.00	2.25	3.19	0.31
2.5E	54	.489	4400	56700	1.44	3.250	3/4 X 3/8	0.84	7.81	8.38	5.31	4.61	2.75	3.91	0.31
3E	80	.7	4000	64500	1.44	4.000	1" X 1/2	1.00	8.65	9.44	6.31	5.61	3.13	4.34	0.31
3.5E	130	1.84	3500	151200	1.81	4.625	1" X 1/2	1.06	9.75	11.00	7.91	6.50	3.53	4.88	0.44
4E	190	3.05	3000	220500	2.41	5.375	1-1/4 X 5/8	1.31	11.17	12.50	9.29	7.50	3.94	5.56	0.67
4.5E	250	4.1	2700	302400	3.00	6.000	1-1/2 X 3/4	1.60	13.00	14.63	10.49	8.50	4.50	6.00	0.60
5E	380	6.14	2500	434700	3.60	6.500	1-1/2 X 3/4	1.67	15.00	16.31	11.50	9.50	5.25	7.00	0.60
5.5E	520	8.1	2200	573300	4.00	7.375	1-3/4 X 3/4	2.00	16.50	18.75	12.81	10.50	5.88	8.28	0.80
6E	650	11.1	2100	749700	4.00	8.000	2" X 3/4	2.47	17.94	20.00	14.00	11.50	7.00	9.19	0.81
7E	850	15.3	2000	1008000	5.00	9.000	2" X 3/4	2.91	20.38	22.75	15.75	13.00	7.76	10.19	1.00

REV	DESCRIPTION	DATE	BY	CHKD	APP'D	DATE	FILE
							GEAR CPLG. FSL DJM DWG Z HUBS REV.

CHART 1

Size		F2	F2.5	F3	F3.5	F4	F4.5	F5	F5.5	F6	F7
"G" hub Separation		0.125	0.19	0.19	0.25	0.25	0.312	0.312	0.312	0.312	0.375
"AP" MAX Separation		0.78	0.94	1.03	1.06	1.31	1.69	1.97	2.06	1.47	1.91
Installation	Offset MAX	0.002	0.003	0.003	0.004	0.005	0.005	0.006	0.007	0.008	0.008
	Angular MAX	0.009	0.011	0.013	0.015	0.018	0.02	0.022	0.024	0.026	0.031
Operating Limits	Offset MAX	0.009	0.012	0.014	0.017	0.02	0.02	0.026	0.027	0.032	0.033
	Angular MAX	0.036	0.045	0.052	0.061	0.072	0.081	0.087	0.096	0.105	0.122
Max Speed		5000	4400	4000	3500	3000	2700	2500	2200	2100	2000
Lube capacity	Weight	5.8 oz	10.5 oz	1 lb	1.25 lb	2 lb	3.5 lb	4.5 lb	6.5 lb	7.25 lb	9.25 lb
	Volume	3/8 pt	3/4 pt	1-1/8 pt	1-1/2 pt	1-7/8 pt	2 qt	2.5 qt	3.5 qt	1 gal	1-1/4 gal
Tightening Torque in-lb.		940	1750	1750	2650	2650	2650	3650	3650	3650	4850