



SLD 900 Shaft Locking Devices Installation and Removal Guide

INTRODUCTION:

The Lovejoy SLD 900 Shaft Locking Device provides an efficient, high capacity, zero backlash, hub-to-shaft connection using a mechanical interference fit. Please review the following Installation and Removal Instructions to ensure proper performance of this SLD.

The following document is intended for the explicit use of Lovejoy customers to aid in the installation of Lovejoy power transmission products. The information may be considered privileged and should only be disseminated as an active part of conducting business with Lovejoy, Inc.

The term, "SLD" refers to Lovejoy's Shaft Locking Devises. Although the SLD may have been properly specified during the design and selection process for a specific shaft or bore size when making your selection, application specifications or equipment may have changed prior to installation. Lovejoy, Inc. provides the information and technical support necessary to ensure the correct and appropriate SLD selection was made relative to the product specifications and limitations of Lovejoy's power transmission products. The end user is ultimately responsible for verifying the suitability of the SLD selection based on the actual service conditions when the SLD is installed.

Correct installation and use of specified bolt tightening torques may lead to longer coupling or hub life, trouble free operation, and a safer operating environment for the SLD and the component hub where the SLD is being used. Please thoroughly review all of the following instructions prior to installing this Shaft Locking Device and placing it in operation. Proper safety guidelines and practices should always be followed during every phase of the installation.

This installation document is considered part of the purchased product and should be retained for future reference.

SAFETY:

Accidents involving rotating equipment may result in loss of life, serious bodily harm, or property damage. The purchaser of this equipment must assure that the equipment is properly assembled, installed, safeguarded, operated, and maintained. This equipment should never be operated at or subjected to conditions that exceed manufacturer's specifications.

Consult all applicable Federal, State, and local laws and regulations covering the safe operation and maintenance of equipment, including, without limitation, the USDOL-OSHA "Lockout / Tag-out" procedure set forth in 29 CFR 1910.147.

Because of the possible danger to persons or property from accidents which may result from the improper use or unapproved modifications of the product, this product must be installed, maintained and operated in accordance with the procedures, standards, and engineering specifications specified in the product literature. To assure safe operation, this product should be inspected in accordance with the instructions described in this document. Proper guards and any suitable safety equipment or procedures as may be necessary, or as may be specified in safety codes, should be installed by the user. Safety equipment, coupling guards, and shields are not provided by, nor are they the responsibility of Lovejoy, Inc.

Symbols and text format used in this document may contain safety information and will appear similar to the following:

 **Warning!** This symbol indicates safety measures which must be observed to avoid personal injury.

Caution! This symbol indicates safety measures which must be observed to avoid damage to coupling.



PRODUCT INSPECTION:

Prior to installation, the coupling should be examined for signs of damage that may have occurred as a result of shipping or handling.

Note: Except for special situations, Lovejoy's external Shaft Locking Devices, or SLD 900 series, (see picture above) are not installed on coupling hubs prior to shipping.

When shipped as part of a complete coupling, the coupling hubs will have been prepared at the Lovejoy factory to accept the specific size SLD as part of the coupling manufacturing process.

Caution! Coupling bore sizes cannot be modified after leaving the factory or the SLD may not properly grip both the hub and the equipment shaft, possibly allowing slippage to occur. When modifications are necessary, consult with Lovejoy Technical Support prior to proceeding with the installation.

For maximum protection, the coupling and all components should be stored in the original packaging. All parts should be measured prior to installation to ensure correctness of parts to meet the application requirements; such as the hub bore diameter, shaft diameter, shaft separation, hub outside diameter (SLD mounting surface), bolt lengths, etc.

REQUIRED TOOLS:

- Micrometer and/or Calipers
- Calibrated Torque Wrench
- Appropriate size Socket

Shaft Locking Device (SLD) PREPARATION:

All exposed surfaces of the SLD and the coupling hub where the SLD will be installed should be thoroughly cleaned prior to the installation to remove any protective coatings normally applied by Lovejoy at the factory intended to protect the coupling surfaces during shipping. A clean cloth dampened with a nonflammable solvent should be sufficient for this cleaning.

 **Warning!** Before beginning the SLD installation, make sure the machinery is made safe. Disconnect and lock out all power to the equipment. No part of the installation should be performed on moving or unstable equipment.

Caution! Lovejoy manufactures the Shaft Locking Device (SLD) interfaces based on the shaft data supplied by the purchaser. Lovejoy is not responsible for inaccurate or incomplete information supplied by the purchaser.

It is the purchasers' responsibility to assure that the SLD and coupling are capable of handling the anticipated loads.

SHAFT LOCKING DEVICE (SLD) SELECTION CONFIRMATION:

Shaft locking devices may have a detrimental influence on the amount of torque the coupling can safely accommodate during operation without slipping.

To calculate the application torque, use the formula:

$$\text{Application Torque (ft-lbs)} = \frac{\text{Horse Power} \times 5252}{\text{RPM}}$$

To calculate the transmissible torque that can be transmitted using the external SLD 900 series shaft locking device, use the formula:

$$T_a \text{ (ft-lbs)} = \frac{(S_a - S_{min})}{(S_{max} - S_{min})} \times (T_{max} - T_{min}) + T_{min}$$

Where: (using charts on pages 3 and 4)

S_a	= actual shaft size (inches)
S_{min}	= minimum shaft size as listed (inches)
S_{max}	= maximum shaft size as listed (inches)
T_a	= actual torque capacity (ft-lbs)
T_{max}	= maximum transmissible torque as listed
T_{min}	= minimum transmissible torque as listed

Compare the two calculated values to ensure the torque capacity of the SLD will accommodate the application torque.

SHAFT LOCKING DEVICE (SLD) INSTALLATION:

Caution! When using Lovejoy SLD shaft locking devices on hubs that were not supplied and prepared by Lovejoy, ensure there is a slight undercut in the hub face (see drawing on page 3 or 4), approximately the same radius as the 'e' dimension.

1. Clean the ID of the SLD 900, the hub, and the hub shoulder that the SLD will be mounted against. Dress or repair any burs, nicks, gouges, dents, or raised metal on either of these surfaces.
2. Lightly lubricate the outside diameter surface on the hub and the inside diameter surface of the ring in the SLD. The torque capacity of the SLD is based on a coefficient of friction of 0.12 for lightly oiled contact surfaces. Therefore, DO NOT use Molybdenum Disulfide lubricants such as Never-Seeze, Molykote, or other similar lubricants to lubricate the hub surface.
3. Clean and lightly lubricate the inside diameter of the hub and the shaft outside diameter. The same rule applies about not using a Molybdenum Disulfide based lubricant.

4. Slide the hub onto the shaft to the proper location. Hand tighten three or four alternating tightening bolts on the SLD at this time while making sure the SLD900 is mounted parallel to the shaft.

5. Position the rest of the equipment to be connected in the correct operational locations. If the hub needs to be moved to facilitate this connection, you should be able to reposition the hub with little or no difficulty.

6. If the coupling is a Lovejoy disc style coupling, install the disc packs, spacer assemblies, and bolts prior to tightening the SLD bolts.

7. Hand tighten all of the SLD tightening bolts. Then double check the SLD to ensure the correct position against the shoulder on the hub. Note. If the coupling is a DIRA or DILRA style adjustable coupling, leave a gap between the SLD and the disc pack bolt heads.

8. Using a calibrated torque wrench, tighten each bolt in either a sequential or star shaped pattern. Tighten each bolt 1/4 turn, repeating this process until the bolts have been tightened to the proper torque setting on the torque wrench. Ensure the torque setting is correct on the torque wrench, then check and tighten each bolt one more time making sure the target torque has been reached.

SHAFT LOCKING DEVICE (SLD) REMOVAL:

Caution! Prior to removing any SLD Shaft Locking Device, check to ensure there is no thrust or torque loads acting on the SLD, hub, shaft, or any component that may be mounted using, or influenced by, the SLD.

1. Loosen each of the tightening bolts by turning the bolts approximately 1/2 turn following a sequential pattern, clockwise or counterclockwise, until the SLD can be moved on the hub. **Since it is possible the SLD collars could 'stick' on the center ring, at no time should any of the bolts be completely removed from the SLD.**



Warning!

DO NOT completely remove the tightening bolts when removing the SLD until the outer collars have released from the inner ring and the SLD can be moved on the hub.

If the collars 'stick' on the inner ring, a sudden release of the collars would involve high separation forces that could cause the collar and/or bolts to release with enough force to cause injury or death.

2. The SLD 900 is a "self-releasing" Shaft Locking Device, however, if the collar 'sticks' on the center ring, make sure all the bolts are threaded at least one full turn in the second collar and lightly tap on the bolt heads with a soft mallet until the collars release from the ring.

3. Once the SLD is loose on the hub, make sure the hub is clean and clear of any rust prior to trying to slide the SLD off the hub. The SLD can be reused as long as there is no damage done to the SLD during the removal process.

Please contact Lovejoy Technical Support at 630-852-0500 with any additional questions or contact apleng@lovejoy-inc.com via email.

Notations

L	= total width of thrust rings (relaxed state)
B	= width of thrust rings (relaxed state)
T	= locking screw specifications
MA	= screw tightening torque
e	= width of gap (relaxed state)
ℓ	= length of contact
D	= outer diameter of disc
d	= hub OD (outside diameter)
ds	= shaft diameter
C	= maximum diametrical clearance (difference between hub diameter and shaft diameter)
Mt	= maximum transmissible torque
T3	= tolerance of hub OD

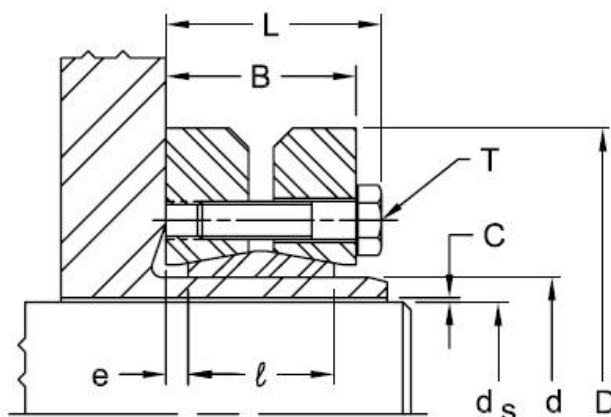

SLD 900 Series Dimensional Data - (Sizes 14 thru 80)

Size	d in	T ₃ Hub OD Tolerance in	ds in	D in	L in	B in	ℓ in	e in	C in	Max Mt ft-lb	T Locking Screws			Weight lb
											Qty	Size	MA ft-lb	
14	0.551	+0 - 0.0013	0.433	1.496	0.591	0.433	0.354	0.039	0.001	22	4	M5	3	0.33
			0.472							37				
16	0.630		0.472	1.614	0.728	0.591	0.433	0.079	0.001	37	5	M5	3	0.44
			0.551							66				
20	0.787		0.551	1.969	0.906	0.748	0.551	0.098	0.001	79	6	M5	3	0.44
			0.728							156				
24	0.945		0.728	1.969	0.906	0.748	0.551	0.098	0.001	120	6	M5	3	0.44
			0.866							210				
30	1.181		0.866	2.362	0.984	0.827	0.630	0.098	0.001	177	6	M5	3	0.66
			1.063							306				
36	1.417		1.063	2.835	1.063	0.906	0.709	0.098	0.001	297	5	M6	9	0.99
			1.220							465				
44	1.732		1.250	3.150	1.142	0.984	0.787	0.098	0.001	454	7	M6	9	1.32
			1.496							719				
50	1.969	1.496	3.543	1.220	1.063	0.866	0.098	0.001	693	8	M6	9	1.76	
		1.654							959					
55	2.165	1.654	3.937	1.339	1.181	0.906	0.138	0.001	885	8	M6	6	2.43	
		1.890							1,401					
62	2.441	1.890	4.331	1.339	1.181	0.906	0.138	0.001	1,328	10	M6	9	2.87	
		2.047							1,770					
68	2.677	1.969	4.528	1.339	1.181	0.906	0.138	0.001	1,475	10	M6	9	3.09	
		2.362							2,286					
75	2.953	2.165	5.433	1.496	1.299	0.984	0.157	0.002	1,844	7	M8	22	3.75	
		2.559							2,876					
80	3.150	2.362	5.709	1.496	1.260	0.984	0.138	0.002	2,360	7	M8	22	4.85	
		2.756							3,393					

Notations

L	= total width of thrust rings (relaxed state)
B	= width of thrust rings (relaxed state)
T	= locking screw specifications
MA	= screw tightening torque
e	= width of gap (relaxed state)
ℓ	= length of contact
D	= outer diameter of disc
d	= hub OD (outside diameter)
d_s	= shaft diameter
C	= maximum diametrical clearance (difference between hub diameter and shaft diameter)
Mt	= maximum transmissible torque
T₃	= tolerance of hub OD

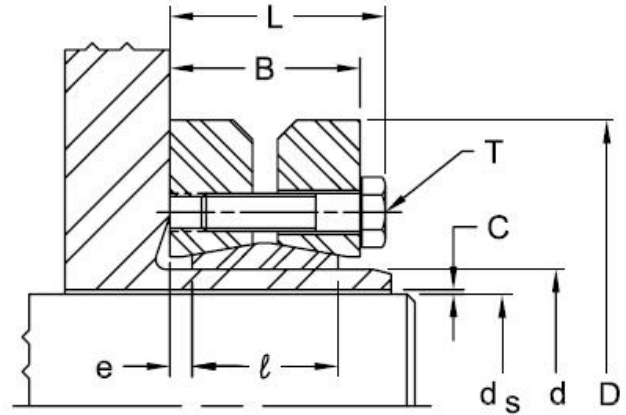

SLD 900 Series Dimensional Data - (Sizes 90 thru 240)

Size	d in	T ₃ Hub OD Tolerance in	d _s in	D in	L in	B in	ℓ in	e in	C in	Max Mt ft-lb	T Locking Screws			Weight lb
											Qty	Size	MA ft-lb	
90	3.543	+0 - 0.0021	2.559	6.102	1.772	1.535	1.181	0.177	0.002	3,467	10	M8	22	7.28
			2.953							5,310				
100	3.937		2.756	6.693	1.949	1.732	1.339	0.197	0.002	5,089	12	M8	22	10.14
			3.150							6,638				
110	4.331		2.953	7.283	2.244	1.969	1.535	0.217	0.002	5,310	9	M10	44	13.01
			3.346							8,113				
115	4.528		3.150	7.402	2.244	1.969	1.535	0.217	0.002	6,269	9	M10	44	13.89
			3.543							8,851				
125	4.921		3.346	8.465	2.402	2.123	1.654	0.236	0.002	8,113	12	M10	44	18.96
			3.740							11,063				
130	5.118		3.543	8.465	2.323	2.047	1.654	0.197	0.002	10,105	12	M10	44	18.08
			3.937							13,424				
140	5.512		3.740	9.055	2.677	2.362	1.811	0.276	0.002	11,063	10	M12	74	22.05
			4.134							14,751				
155	6.102	4.134	10.433	2.756	2.441	1.969	0.236	0.003	14,751	12	M12	74	33.07	
		4.528							19,177					
165	6.496	4.528	11.417	3.071	2.677	2.205	0.236	0.003	26,552	8	M16	184	48.50	
		4.921							32,453					
175	6.890	4.921	11.811	3.071	2.677	2.205	0.236	0.003	32,453	8	M16	184	50.71	
		5.315							36,141					
185	7.283	5.315	12.992	3.780	3.386	2.795	0.295	0.003	44,254	10	M16	184	79.37	
		5.709							47,942					
195	7.677	5.512	13.780	3.780	3.386	2.795	0.295	0.003	48,679	12	M16	184	88.18	
		6.102							60,480					
200	7.874	5.906	13.780	3.780	3.386	2.795	0.295	0.003	56,055	12	M16	184	105.82	
		6.299							65,643					
220	8.661	6.299	14.567	4.488	4.094	3.465	0.315	0.003	70,068	15	M16	184	119.05	
		6.693							81,132					
240	9.449	6.693	15.945	4.803	4.291	3.622	0.335	0.003	88,507	12	M20	361	147.71	
		7.480							118,010					

Lovejoy, Inc.
World Headquarters
 2655 Wisconsin Avenue
 Downers Grove, IL 60515
 630-852-0500
 info@lovejoy-inc.com



www.lovejoy-inc.com

ISO 9001:2008 Certified

Version Date: 27-June-2012