

# FARR Couplings

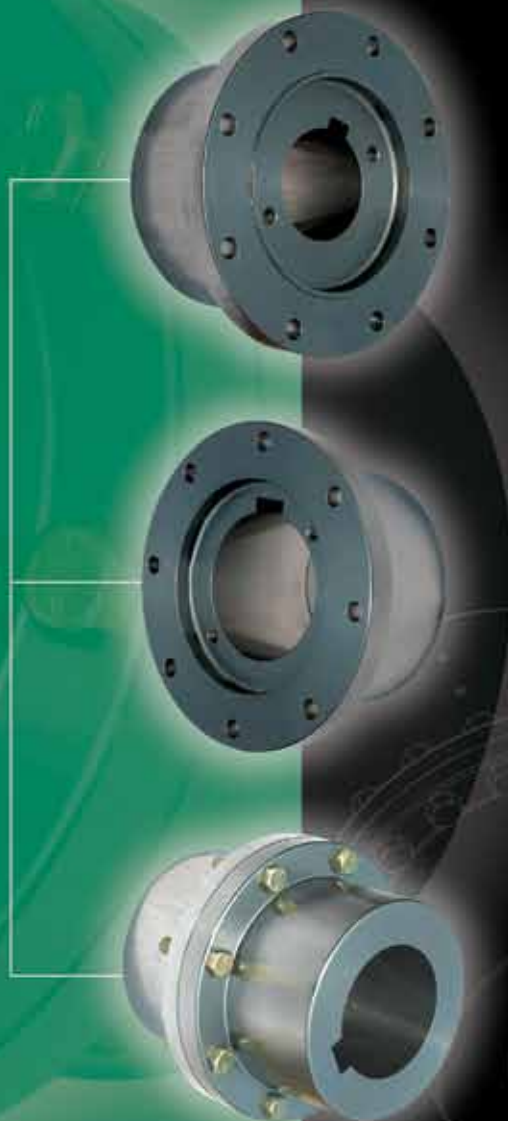

where the world turns for couplings



# FARR Coupling Overview and Performance Data

The FARR Coupling is used when a rigid connection is required between the low speed shaft of a gearbox and the head shaft of a conveyor, bucket elevator, mixer or any over-hung or suspended load. When sized properly, the FARR Coupling will carry the application torque, weight of gearbox, motor and swing plate. In the case of a mixer, it will carry the weight of the shaft and impeller, thrust forces and resulting bending moments.

Components of a FARR Coupling consist of male and female piloted hubs made from 4140 alloy steel. The hubs are extended to assure 80% hub to shaft contact. Keeper plates are included for safety. The two hubs are assembled with Grade 8 bolts and Grade "C" Prevailing Torque nuts. Standard coupling sizes have a nominal torque range from 11,300 to 5,736,000 in-lbs. Larger sizes are available depending on the application.

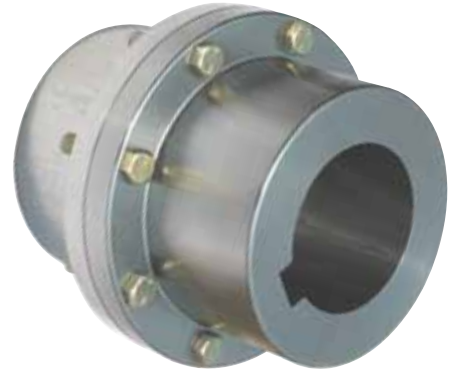

## Features

- Heat Treated 4140 alloy steel
- Male and Female pilots
- Increased Torque Capacity
- Grade 8 Bolts / Grade "C" Prevailing Torque Nuts
- Extended length through bore
- Keeper Plate design

## FARR Performance Data

Size	Torque Capacity		Torque Peak		Max Speed Unbalanced RPM	Bolt Size		Bolt Circle Dia in	Tightening Torque	
	in-lbs	Nm	in-lbs	Nm		Qty	in		ft-lb	Nm
1	11,300	1 277	22,600	2 554	6,000	6	1/4 - 28	3.750	10	14
1.5	22,700	2 565	45,400	5 130	5,500	8	3/8 - 24	4.812	30	41
2	39,000	4 407	78,000	8 814	5,000	6	1/2 - 20	5.875	75	102
2.5	69,300	7 830	138,600	15 660	4,400	6	5/8 - 18	7.125	150	203
3	118,000	13 333	236,000	26 667	4,000	8	5/8 - 18	8.125	150	203
3.5	177,000	20 000	354,000	40 000	3,500	8	3/4 - 16	9.500	220	29 8
4	263,400	29 763	526,800	59 525	3,000	8	3/4 - 16	11.000	220	298
4.5	354,000	40 000	708,800	80 000	2,700	10	3/4 - 16	12.000	220	298
5	508,600	57 469	1,017,200	114 938	2,500	8	7/8 - 14	13.500	250	339
5.5	670,700	75 785	1,341,400	151 570	2,200	14	7/8 - 14	14.500	250	339
6	877,100	99 107	1,754,200	198 215	2,100	14	7/8 - 14	15.750	250	339
7	1,179,300	133 254	2,358,600	266 508	2,000	16	1 - 14	18.250	400	542
8	1,721,000	194 463	3,442,000	388 926	1,900	16	1-1/8 - 12	20.750	550	746
9	2,376,000	268 475	4,752,000	536 950	1,800	18	1-1/4 - 12	23.250	750	1017
10	3,277,000	370 282	6,554,000	740 565	1,550	18	1-3/8 - 12	25.250	1000	1356
11	4,506,000	509 152	9,012,000	1 018 305	1,400	18	1-1/2 - 12	27.500	1500	2034
12	5,736,000	648 136	11,472,000	1 296 272	1,300	18	1-1/2 - 12	30.000	1500	2034

Note: ■ Larger size couplings available - Please contact Lovejoy Application Engineering.

# FARR Coupling Dimensional Data

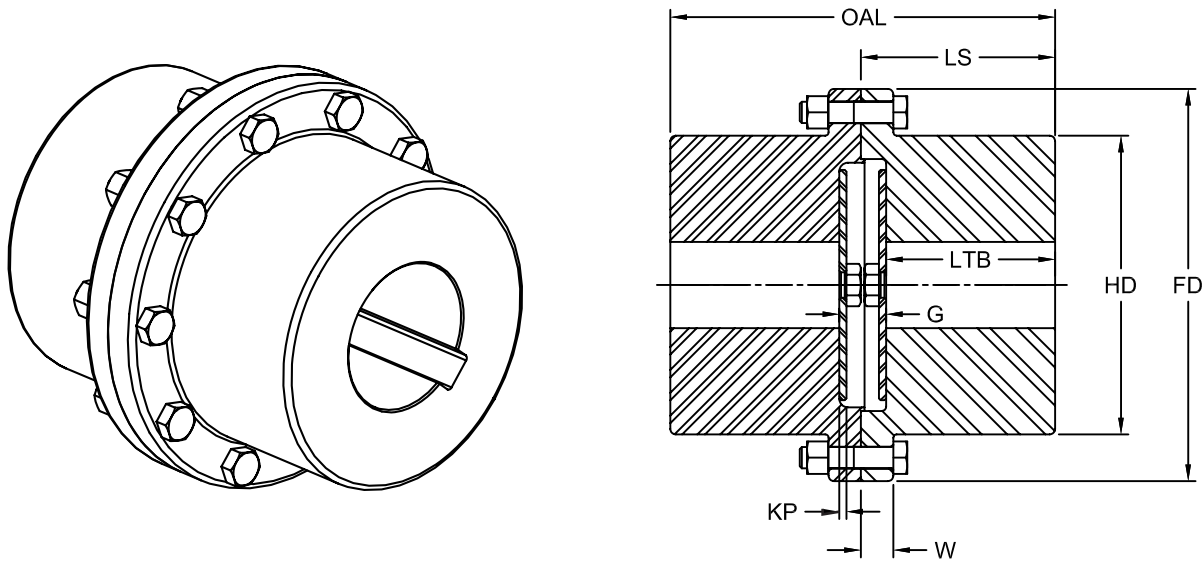

## FARR Dimensional Data

Size	Max Bore		Rough Stock Bore		OAL	LS	LTB	G (BSE)	KP	W	FD	HD	Weight <sup>1</sup>	
	in	mm	in	mm									in	in
1	1.875	48	Solid	Solid	5.88	2.94	2.38	1.12	0.25	0.56	4.56	3.06	12.4	5.62
1.5	2.312	58	Solid	Solid	6.64	3.32	2.50	1.64	0.25	0.75	6.00	3.94	24.7	11.19
2	2.812	72	Solid	Solid	7.21	3.61	2.85	1.51	0.25	0.75	7.00	4.86	38.9	17.63
2.5	3.500	89	Solid	Solid	8.77	4.39	3.63	1.51	0.25	0.88	8.38	5.83	67.4	30.58
3	4.125	105	Solid	Solid	9.44	4.72	3.90	1.51	0.25	0.88	9.44	6.83	95.0	43.10
3.5	5.375	136	Solid	Solid	10.63	5.32	4.50	1.63	0.25	1.13	11.00	7.88	139.0	63.07
4	6.000	152	Solid	Solid	11.87	5.94	5.12	1.63	0.25	1.13	12.50	9.25	207.1	93.92
4.5	6.875	174	Solid	Solid	13.37	6.69	5.87	1.63	0.25	1.13	13.63	10.38	279.8	126.90
5	7.500	190	4.65	118	14.87	7.44	6.62	1.63	0.25	1.50	15.31	11.50	367.1	166.50
5.5	8.500	216	4.65	118	16.37	8.19	7.37	1.63	0.25	1.50	16.75	12.73	490.4	222.50
6	9.250	235	5.52	140	17.87	8.94	8.12	1.63	0.25	1.00	18.00	14.00	597.8	271.20
7	10.500	266	5.52	140	20.89	10.45	9.01	2.88	0.50	1.13	20.75	15.75	894.0	405.70
8	12.250	311	7.40	188	24.78	12.39	11.10	2.88	0.50	1.31	23.25	18.35	1390.0	630.50
9	13.500	343	8.52	216	26.49	13.25	11.81	2.88	0.50	1.50	26.00	20.38	1848.0	838.20
10	14.875	378	8.52	216	27.59	13.80	12.36	2.88	0.50	1.50	28.00	22.30	2302.0	1044.00
11	16.250	412	11.02	280	30.00	15.00	13.13	3.75	0.75	1.63	30.50	24.36	2884.0	1308.00
12	17.500	444	11.02	280	31.50	15.75	13.88	3.75	0.75	1.63	33.00	26.62	3682.0	1670.00

Notes: ■ 1 Indicates: Total coupling weight with one maximum bore hub and one Rough Stock Bore hub.

■ Interference Bores are standard unless otherwise specified.

■ Bores and Keyways are machined to meet dimension tolerances defined in ANSI / AGMA 9002-B04 for inch and ISO 286-2 for metric.

# FARR Coupling Selection Guide

## A. Obtain The Following Information:

- Application
- Horsepower & RPM
- Gearbox (Reducer) Ratio
- Output Speed
- All Shaft Sizes
- Overhang Load
- Lever Arm

(Distance from end of Gearbox output Shaft to Center-Line of Gearbox or Center Line of Gravity)

## B. Calculate Application Torque:

$$T \text{ (in-lb)} = \frac{HP \times 63025}{RPM}$$

## C. Calculate Design Torque by applying 2.0 Service Factor to application torque.

$$2.0 \times T \text{ (in-lb)} = \text{Design Torque}$$

## D. Select coupling with a torque capacity equal to or greater than the Design Torque from the Performance Data table.

## E. Verify that the Bore capacity of the coupling will meet the application shaft requirements.

## F. The Male pilot hub to always be used on the Reducer (Gearbox or Driver) shaft and the Female pilot hub to always be used on the Head (Driven) shaft.

## G. Drive System Analysis must be performed by Lovejoy Application Engineering to verify coupling selection.

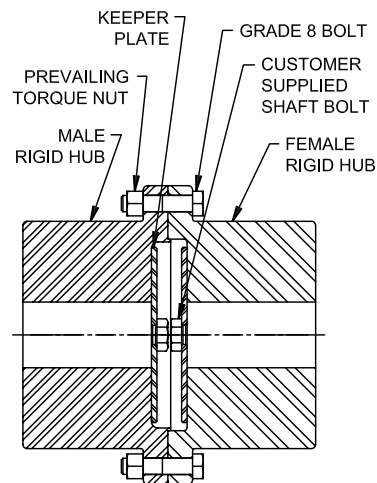

Male Piloted Hub

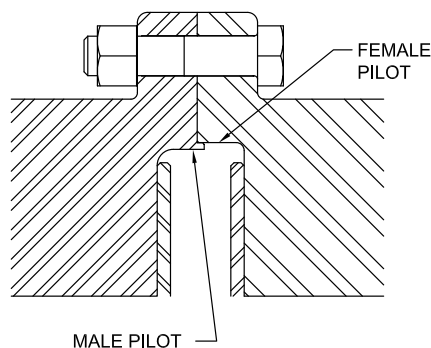

Female Piloted Hub

# FARR Coupling Selection Form

When selecting a FARR style coupling, please provide Lovejoy Application Engineering with the information requested in the following worksheet.

Please send form to Lovejoy at [appleng@lovejoy-inc.com](mailto:appleng@lovejoy-inc.com) or fax to 800-446-0878.

Customer: \_\_\_\_\_ Date: \_\_\_\_\_

Contact: \_\_\_\_\_ email address: \_\_\_\_\_

Phone Number: \_\_\_\_\_ Fax Number: \_\_\_\_\_

Location: \_\_\_\_\_

Application Description: \_\_\_\_\_

Motor Horse Power: \_\_\_\_\_ Motor Speed (RPM): \_\_\_\_\_

Reducer Ratio (Gearbox): \_\_\_\_\_ Output Speed (RPM): \_\_\_\_\_

Reducer (Driver) Output Shaft Diameter: \_\_\_\_\_ Keyway Width: \_\_\_\_\_ Height: \_\_\_\_\_

Head (Driven) Shaft Diameter: \_\_\_\_\_ Keyway Width: \_\_\_\_\_ Height: \_\_\_\_\_

Lever Arm: \_\_\_\_\_ (The lever arm is the distance from the end of the gearbox output shaft to the Centerline of Gravity of the Motor Gearbox, or the Centerline of the Gearbox)

Weight of Overhanging Load (cantilevered load): \_\_\_\_\_ (Includes Motor, Gearbox, and Mounting Plate)

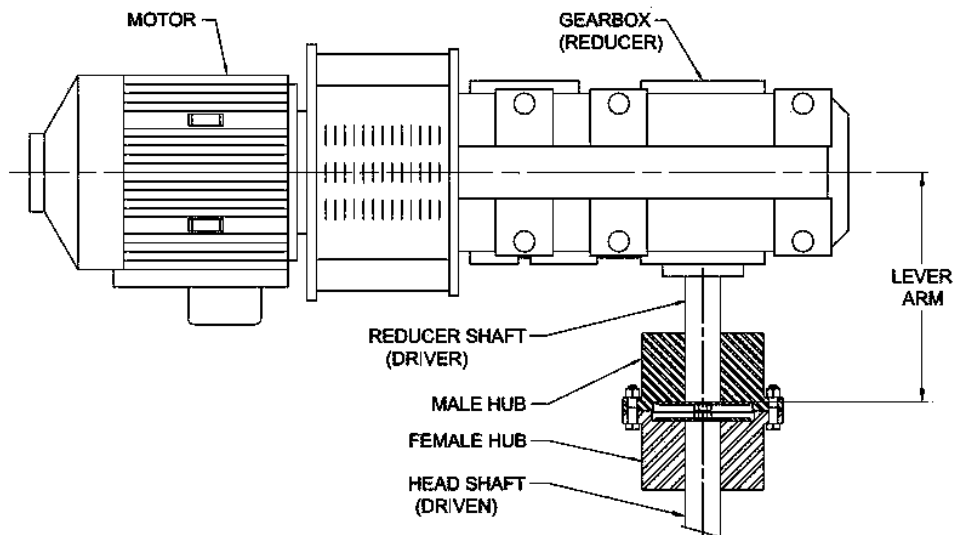

## **Safety Warning**

---

When using Lovejoy products, you must follow these instructions and take the following precautions. Failure to do so may cause the power transmission product to break and parts to be thrown with sufficient force to cause severe injury or death.

Refer to this Lovejoy Catalog for proper selection, sizing, horsepower, torque range, and speed range of power transmission products, including elastomeric elements for couplings. Follow the installation instructions included with the product, and in the individual product catalogs for proper installation of power transmission products. Do not exceed catalog ratings.

During start up and operation of power transmission product, avoid sudden shock loads. Coupling assembly should operate quietly and smoothly. If coupling assembly vibrates or makes beating sound, shut down immediately, and recheck alignment. Shortly after initial operation and periodically thereafter, where applicable, inspect coupling assembly for: alignment, wear of elastomeric element, bolt torques, and flexing elements for signs of fatigue. Do not operate coupling assembly if alignment is improper, or where applicable, if elastomeric element is damaged, or worn to less than 75% of its original thickness.

Do not use any of these power transmission products for elevators, man lifts, or other devices that carry people. If the power transmission product fails, the lift device could fall resulting in severe injury or death.

For all power transmission products, you must install suitable guards in accordance with OSHA and American Society of Mechanical Engineers Standards. Do not start power transmission product before suitable guards are in place. Failure to properly guard these products may result in severe injury or death from personnel contacting moving parts or from parts being thrown from assembly in the event the power transmission product fails.

If you have any questions, contact the Lovejoy Engineering Department at 1-630-852-0500.

# Lovejoy® Products



Jaw Couplings



Sier-Bath®  
Gear Couplings



Disc Couplings



ROSTA®



Grid Couplings



Jaw In-Shear Couplings



Curved Jaw Couplings



Universal Joints



Torsional Couplings



Motion Control Couplings



S-Flex Couplings



Shaft Locking Devices



ISO 9001:2000 Certified

## Lovejoy, Inc. World Headquarters

2655 Wisconsin Avenue  
Downers Grove, IL 60515 U.S.A.  
Phone: 630-852-0500  
Fax: 630-852-2120  
info@lovejoy-inc.com

## Raja-Lovejoy GmbH

Friedrichstrasse 6  
D-58791 Werdohl  
Germany  
Phone +49 (0) 23 39 / 5 09-0  
Fax +49 (0) 23 92 / 5 09-509  
info@raja-lovejoy.com  
www.raja-lovejoy.com

## Lovejoy Canada

171 Superior Boulevard  
Mississauga, Ontario  
Canada L5T 2L6  
Phone: 905-670-9421  
Fax: 905-670-4594  
lovejoycanada@lovejoy-inc.com

[www.lovejoy-inc.com](http://www.lovejoy-inc.com)

Lovejoy® is a registered trademark of Lovejoy, Inc. All other trademarks, brands, and names mentioned in this publication are property of their respective owners.